

KOMATSU®

PC400LC-7 With Tier 3 Engine

FLYWHEEL HORSEPOWER
257 kW **345 HP** @ 1900 rpm

OPERATING WEIGHT
43500–46275 kg
95,901 – 102,018 lb

BUCKET CAPACITY
1.12–2.87 m³ **1.47–3.75 yd³**

PC
400
LC

HYDRAULIC EXCAVATOR



Photo may include optional equipment

WALK-AROUND

Productivity Features

- **High Production and Low Fuel Consumption**

High power, working performance and fuel efficiency improve production and fuel costs.

- **Excellent Machine Stability**

Large counterweight offers superior machine stability and balance.

- **Higher Lifting Capacity**

Lifting mode is provided for superb lifting operation.

- **Large Digging Force**

Pressing the Power Max function button temporarily increases the digging force 7%.

- **Automatic Three-Speed Travel**

- **Two-Mode Setting for Boom**

Switch selection allows either powerful digging or smooth boom operation.

- **Multi-Function Color Monitor**

- Working mode selection
- Self-diagnostic with EMMS
- Attachment hydraulic oil flow adjustment

Easy Maintenance

- Long replacement interval of engine oil, engine oil filter, hydraulic oil and hydraulic filter
- Equipped with 10 micron fuel pre-filter as standard equipment (with water separator)
- Side-by-side cooling configuration enables individual cooling modules to be serviced
- Equipped with EMMS monitoring system
- Easy access to engine oil filter and fuel drain valve
- Large fuel tank capacity
- KOMTRAX

Safety Features

- High visibility cab
- OPG top guard level 2 capable, with optional bolt on top guard
- Engine neutral start with lock lever
- Slip-resistant plates for improved foot traction



KOMTRAX™

KOMTRAX equipped machines can send location, SMR and operation maps to a secure website utilizing wireless technology. Machines also relay error codes, cautions, maintenance items, fuel levels, and much more.

FLYWHEEL HORSEPOWER
257 kW 345 HP @ 1900 rpm

OPERATING WEIGHT
43500 – 46275 kg
95,901 – 102,018 lb

BUCKET CAPACITY
1.12 – 2.87 m³
1.47 – 3.75 yd³

Ecology and Economy Features

- Low emission engine
A powerful turbocharged and air-to-air aftercooled Komatsu SAA6D125E-5 engine provides 257 kW **345 HP**. This engine is EPA Tier 3 and EU stage 3A emission certified, without sacrificing power or machine productivity.
- Economy mode reduces fuel consumption
- Low operational noise

Excellent Reliability and Durability

- Highly rigid work equipment
- Sturdy frame structure
- Reliable Komatsu manufactured major components
- Highly reliable electronic devices
- Reduced revolving frame damage

Large Comfortable Cab

- Multi-position controls
- Low cab noise
- Low vibration with cab damper mounting
- Highly pressurized cab with automatic air conditioner



Photo may include optional equipment

Variable Track Gauge (optional)

- Greatly increases lateral stability
- Compliant with transportation regulations

GALEO

Komatsu's highly productive, innovative technology, environmentally friendly machines built for the 21st century.

PC400LC-7 HYDRAULIC EXCAVATOR

PRODUCTIVITY FEATURES



Komatsu's new "ecot3" engines are designed to deliver optimum performance under the toughest of conditions while meeting the latest environmental regulations. This engine is Tier 3 EPA, EU Stage 3A and Japan emissions certified. "ecot3" – ecology and economy combined with Komatsu technology to create a high performance engine without sacrificing power or productivity.

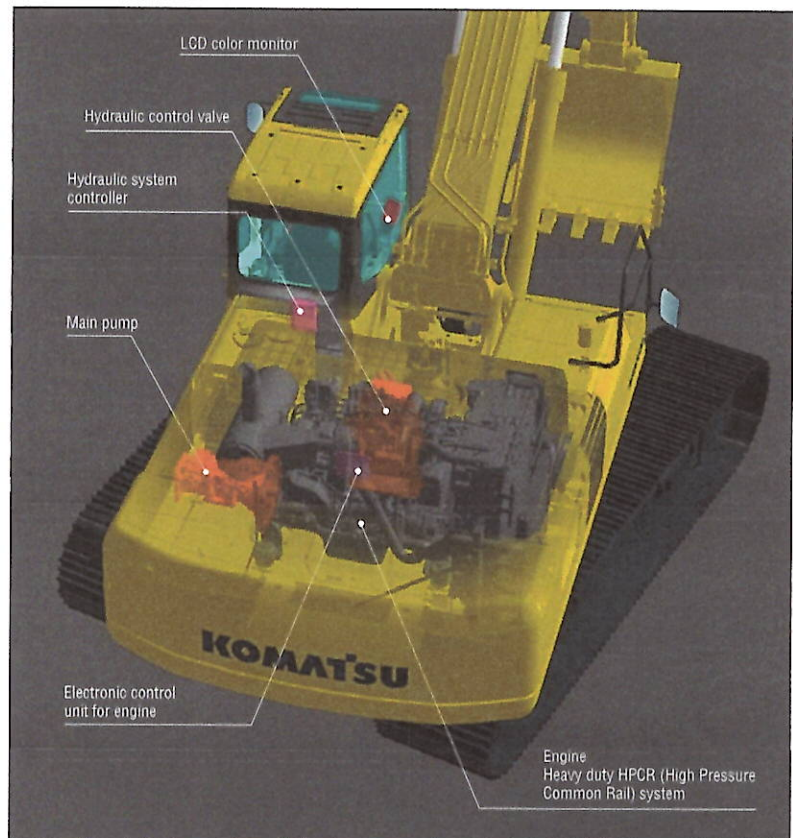

Environment-Friendly Clean Engine

The PC400LC-7 gets its exceptional power and work capacity from a Komatsu SAA6D125E-5 engine. Output is 257 kW **345 HP**, providing increased hydraulic power and improved fuel efficiency.

The Komatsu SAA6D125E-5 engine is EPA Tier 3 and EU stage 3A emission certified with NOx emission reduced by 38%.

The SAA6D125E-5 engine adopts the electronically controlled Heavy Duty HPCR (High Pressure Common Rail) fuel injection system and the world's first cooled EGR system with electronically controlled bypass-assist type venturi.

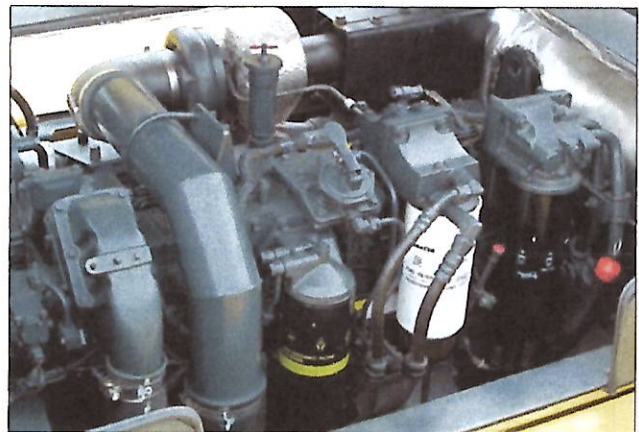

Low Operation Noise

The dynamic noise is lowered by 1 dB, realizing low noise operation.

Excellent Machine Stability

Large counterweight offers superior machine stability and balance.

Large Digging Force

With the one-touch Power Max function digging force has been further increased (8.5 seconds of operation).

Maximum arm crowd force (ISO):

200 kN (20.4t) ➔ **214 kN (21.8t)** (with Power Max) **7% UP**

Maximum bucket digging force (ISO):

256 kN (26.1t) ➔ **275 kN (28.0t)** (with Power Max) **7% UP**

*Measured with Power Max function, 3380 mm 11'1" arm and ISO rating

Smooth Loading Operation

Two return hoses improve hydraulic performance. In the arm out function, a portion of the oil is returned directly to the tank providing smooth operation.

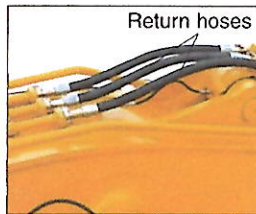

Two-Mode Setting for Boom

Smooth mode provides easy operation for gathering blasted rock or scraping down operation. When maximum digging force is needed, switch to Power mode for more effective excavating.

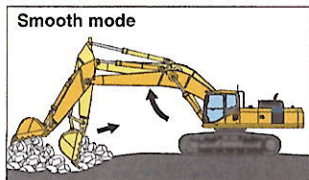

Boom floats upward, reducing lifting of machine front. This facilitates gathering blasted rock and scraping down operations.

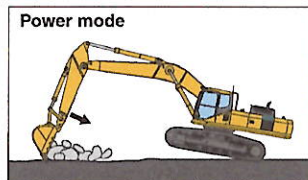

Boom pushing force is increased, ditch digging and box digging operation on hard ground are improved.

Variable Track Gauge (optional)

- Lateral stability is significantly improved when operating with the gauge extended.
- Lateral stability is greatly and effectively increased (compared with the fixed gauge version).
- With track frames retracted, overall width complies with many local transportation regulations.

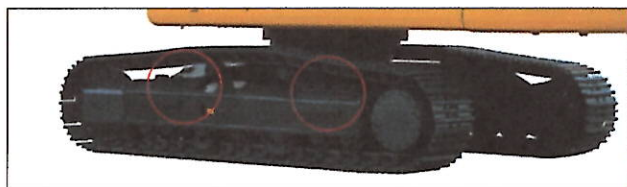

Working Mode Selection

The PC400LC-7 excavator is equipped with four working modes (P, E, L and B). Each mode is designed to match engine speed, pump flow, and system pressure with the current application. This provides the flexibility to match equipment performance to the job at hand.

Working Mode	Application	Advantage
P	Power mode	<ul style="list-style-type: none"> • Maximum production/power • Fast cycle time
E	Economy mode	<ul style="list-style-type: none"> • Excellent fuel economy
L	Lifting mode	<ul style="list-style-type: none"> • Hydraulic pressure is increased by 7%
B	Breaker mode	<ul style="list-style-type: none"> • Optimum engine rpm and hydraulic flow for breaker operation



- P** Power mode
- E** Economy mode
- L** Lifting mode
- B** Breaker mode

Economy Mode

Economy mode is environmentally friendly. Fuel consumption is reduced 11% (compared with PC400LC-7 Power mode).

Lifting mode

When the lifting mode is selected, lifting capacity is increased 7% by raising hydraulic pressure.

Breaker mode

Flow can be adjusted from the cab to match various attachment requirements.

Automatic Three-Speed Travel

Travel speed is automatically shifted between high/mid/low speeds according to the pressure required to travel.

WORKING ENVIRONMENT

PC400LC-7 cab interior is spacious and provides a comfortable working environment...

Large Comfortable Cab

Multi-Position Controls

The multi-position, PPC (pressure proportional control) levers allow the operator to work in comfort while maintaining precise control. A double-slide mechanism allows the seat and controllers to move together or independently, allowing the operator to position the seat and controllers for maximum productivity and comfort.



Seat Sliding Amount: 340 mm 13.4", increased 120 mm 4.7"

Low Cab Noise

The cab is highly rigid and has excellent sound absorption.

Through improvements in noise source reduction and the use of low-noise engine, hydraulic equipment, and air conditioner, this machine generates a low level of noise.

Low Vibration with Cab Damper Mounting

PC400LC-7 uses a multi-layer viscous mount system that incorporates longer stroke and the addition of a spring. The new cab damper mounting, combined with a high rigidity deck, aids vibration reduction at the operator seat.

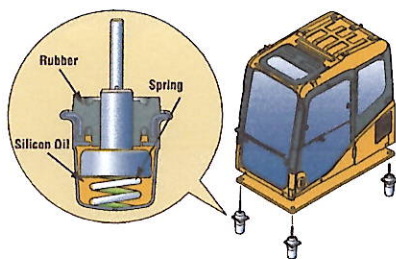

Comfortable Cab

A wide spacious cab includes a seat with a reclining backrest. The seat height and longitudinal incline are easily adjusted using a pull-up lever. The seat can be reclined to a fully-flat state with the headrest attached.



Pressurized Cab

With automatic air conditioner, air filter and a higher internal air pressure (+6.0 mm Aq +0.2" Aq), external dust is prevented from entering the cab.

Automatic Air Conditioner

A 6900 kcal 27,400 Btu air conditioner is utilized. The bi-level control function keeps the operator's head cool and feet warm. This improved air flow function keeps the inside of the cab comfortable throughout the year. The defroster function keeps the cab glass clear.



SAFETY FEATURES

Safety Features

Cab

OPG top guard level 2 capable, with optional bolt-on top guard.

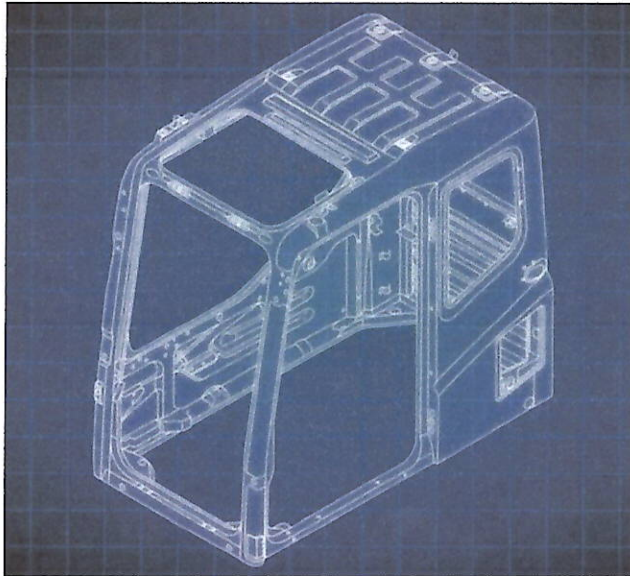

OPG Level 2 Top Guard (optional)

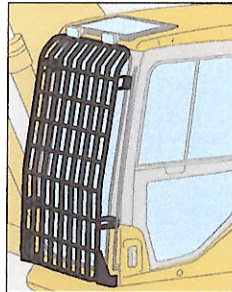

Front Full Guard Level 2 (optional)

Wide Visibility

Highly rigid cab allows for increased glass area and provides superior all-around visibility of work area.



Slip-Resistant Plates

Highly durable slip-resistant plates maintain superior traction performance for the long term.



Lock Lever

Makes all hydraulic cab controls inoperable. Neutral start function allows machine to be started only in lock position.



Pump/Engine Room Partition

Pump/engine room partition prevents oil from spraying onto the engine if a hydraulic hose should fail.

Thermal and Fan Guards

Thermal and fan guards are placed around high-temperature parts of the engine and fan drive.

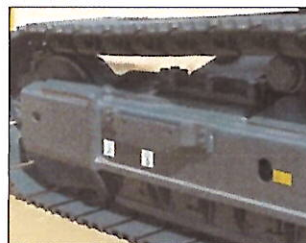

Large Serrated Steps



Large Hand Rail

MAINTENANCE FEATURES

Self-Diagnostic Monitor

The PC400LC-7 features the most advanced diagnostics system in the industry. The Komatsu-exclusive system identifies maintenance items, reduces diagnostic times, indicates oil and filter replacement hours and displays error codes.

Continuous Machine Monitoring System

When turning starting switch ON, check-before-starting items and caution items appear on the liquid crystal panel. If abnormalities are found, a warning lamp blinks and a warning buzzer sounds. The continuous machine condition checks help prevent the development of serious problems and allows the operator to concentrate on the work at hand.

Easy Maintenance

Komatsu designed the PC400LC-7 to have easy service access. We know by doing this, routine maintenance and servicing are more likely to be performed, which can mean a reduction in costly downtime later on. Here are some of the many service features found on the PC400LC-7.

Easy Radiator Cleaning

Since radiator and oil cooler are arranged in side-by-side modules, it is easy to clean, remove and install them.

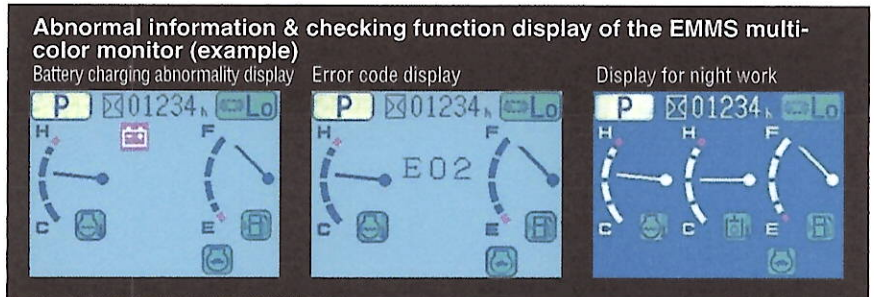
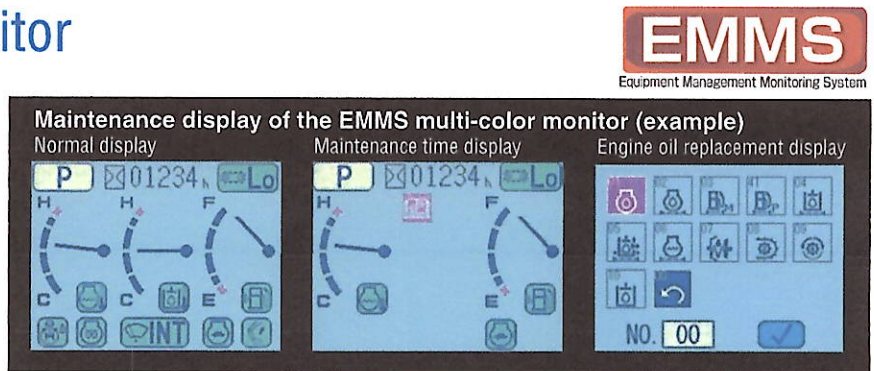

Abnormalities Display with Code

When an abnormality occurs during operation, a user code is displayed. When an important user code is displayed, a caution lamp blinks and a warning buzzer sounds to alert the operator to take action.

Oil Maintenance Function

When machine exceeds oil or filter replacement time, the oil maintenance monitor display lights to inform operator.

Trouble Data Memory Function

Monitor stores abnormalities for effective troubleshooting.

Easy Access to Engine Oil Filter and Fuel Drain Valve

Engine oil dipstick and fill, and fuel filter are mounted on the same side to improve accessibility.

Fuel drain valve and engine oil filter are remotely mounted to improve accessibility.



Fuel Drain Valve

Equipped with Fuel Pre-Filter (with water separator)

Removes water and contaminants in the fuel to prevent fuel problems.



Equipped with Eco-Drain Valve as Standard

Provides for easier and cleaner engine oil changes.

Maintenance Costs Reduced

Long Replacement Interval of Hydraulic and Engine Oil and Filters

High performance filters are used in the hydraulic circuit and engine. Longer hydraulic oil, hydraulic oil filter, engine oil and engine oil filter element replacement intervals significantly reduce maintenance costs.

Engine oil	
Engine oil filter	every 500 hours
Hydraulic oil	every 5000 hours
Hydraulic oil filter	every 1000 hours



Long Work Equipment Greasing Interval

High quality BMRC bushings and resin shims are utilized in the work equipment pins, excluding bucket, extending greasing interval to 500 hours.

Large Capacity Air Cleaner

Large capacity air cleaner is comparable to those installed in larger machines. The large air cleaner extends filter element life and service intervals.



Large Fuel Tank Capacity

Large fuel tank capacity extends operating hours before refueling. Fuel tank is treated for rust prevention and improved corrosion resistance.

High Pressure In-Line Filters

In-line filters are provided at the outlet port (pressure side) of each pump to protect the hydraulic system from contamination due to the unlikely event of a pump failure.

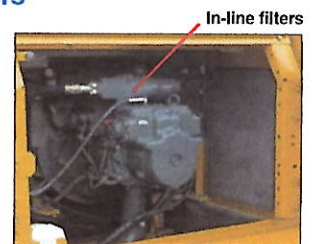

RELIABILITY AND FEATURES

High Rigidity Work Equipment

Boom and arms are constructed of thick plates of high tensile strength steel. In addition, these structures are designed with large cross-sectional areas and generous use of castings. The result is working attachments that exhibit long term durability and high resistance to bending and torsional stress.

Sturdy Frame Structure

The revolving frame, center frame and undercarriage are designed by using the most advanced three-dimensional CAD and FEM analysis technology.

Reliable Components

All of the major machine components such as engine, hydraulic pumps, hydraulic motors and control valves are exclusively designed and manufactured by Komatsu.

Highly Reliable Electronic Devices

Exclusively designed electronic devices have passed severe testing.

- Controllers
- Sensors
- Connectors
- Heat resistant wiring

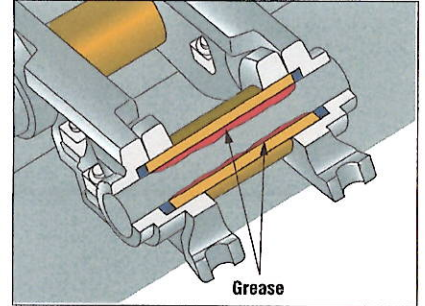
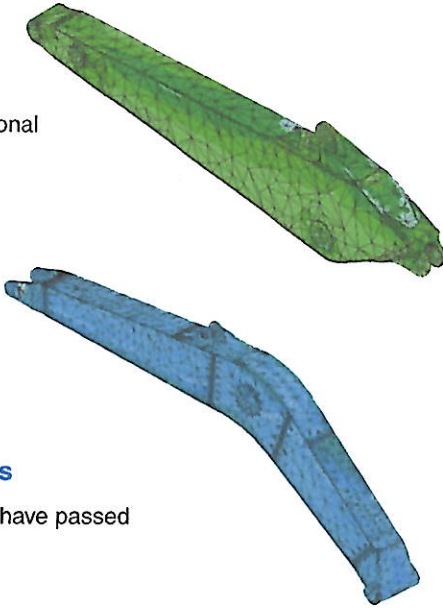

Grease Sealed Track

PC400LC-7 uses grease sealed tracks for extended undercarriage life.

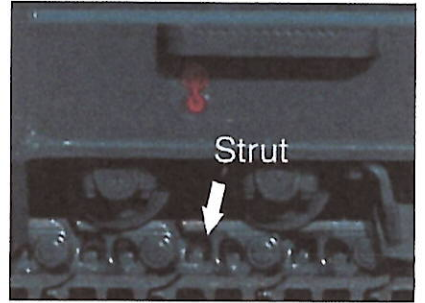

Track Link with Strut

PC400LC-7 uses track links with strut, providing superb durability

Metal Guard Rings Protect All the Hydraulic Cylinders and Improve Reliability

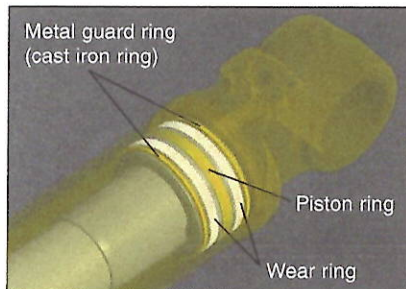

DT-Type Connectors

DT-type connectors seal tightly and have higher reliability.

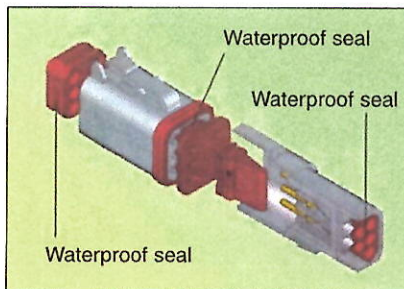

O-Ring Face Seal

Hydraulic hoses are equipped with O-ring seals versus conventional taper seal to provide extended leak-free life.



Reduced Revolving Frame Damage

Damage to the revolving frame is reduced by increasing the clearance between the revolving frame and track.

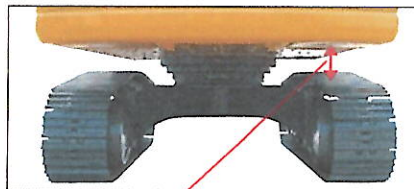

Clearance:
approx. 200mm 7.9"

LCD Multi-Function Color Monitor

LCD (Liquid Crystal Display) Color Graphics Screen

LCD multi-color monitor can display color graphics as well as character display. Color variation in the display screen contributes to improved visibility.

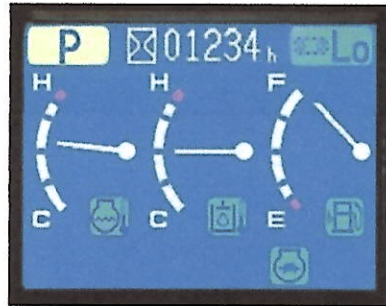

Display screen during nighttime hours (working light "ON")

Hydraulic Pump Oil Flow Adjustment System

When installing attachments, hydraulic pump flow adjustments can be made to match attachment requirements. Selection is possible through the LCD monitor.

Breaker mode selected, one-way flow.

Flow rate can be adjusted according to the breaker requirement.

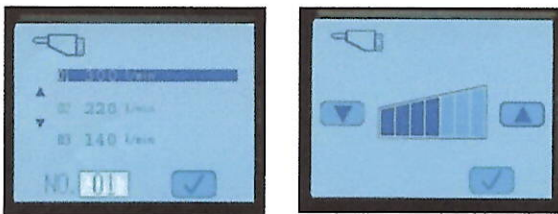

Flow rate fine adjustment display screen

P or E mode selected, two-way flow (thumb, shear)

Flow rate can be adjusted according to the attachment requirements. When work equipment and the attachment are operated simultaneously, hydraulic flow is distributed to maintain smooth compound operation.

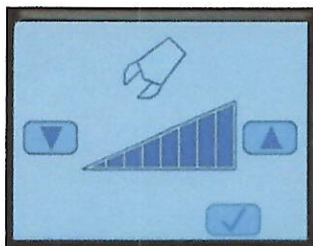

Flow rate fine adjustment display screen



Indicators

- 1 Working mode
- 2 Service meter
- 3 Travel speed
- 4 Engine water temperature gauge
- 5 Hydraulic oil temperature gauge
- 6 Fuel gauge
- 7 Swing parking brake
- 8 Preheater
- 9 Wiper
- 10 Auto-decelerator
- 11 Power Max.

Switches

- 1 Power mode
- 2 Economy mode
- 3 Lifting mode
- 4 Breaker mode
- 5 Buzzer cancel
- 6 Selector switch
- 7 Auto-decelerator
- 8 Travel speed selection
- 9 Screen adjustment switch
- 10 Maintenance mode
- 11 Windshield wiper
- 12 Windshield washer
- 13 Input control switches

PC400LC-7 HYDRAULIC EXCAVATOR

SPECIFICATIONS



ENGINE

Model Komatsu SAA6D125E-5
 Type Water-cooled, 4-cycle, direct injection
 Aspiration Turbocharged, aftercooled, cooled EGR
 Number of cylinders 6
 Bore 125 mm **4.92"**
 Stroke 150 mm **5.91"**
 Piston displacement 11.04 ltr **674 in³**
 Horsepower:
 SAE J1995 Gross 270 kW **362 HP**
 ISO 9249 / SAE J1349 Net 257 kW **345 HP**
 Rated rpm 1900 rpm
 Fan drive type Mechanical
 Governor All-speed control, electronic

EPA Tier 3 and EU stage 3A emission certified.



HYDRAULICS

Type HydrauMind (Hydraulic Mechanical Intelligence New Design) system, closed-center system with load sensing valves and pressure compensated valves
 Number of selectable working modes 4
 Main pump:
 Type Variable displacement piston type
 Pumps for Boom, arm, bucket, swing, and travel circuits
 Maximum flow 690 ltr/min **182 U.S. gal/min**
 Supply for control circuit Self-reducing valve
 Hydraulic motors:
 Travel 2 x axial piston motors with parking brake
 Swing 1 x axial piston motor with swing holding brake
 Relief valve setting:
 Implement circuits 37.3 MPa **380 kgf/cm² 5,400 psi**
 Travel circuit 37.3 MPa **380 kgf/cm² 5,400 psi**
 Swing circuit 27.9 MPa **285 kgf/cm² 4,050 psi**
 Pilot circuit 3.2 MPa **33 kgf/cm² 470 psi**
 Hydraulic cylinders:
 (Number of cylinders – bore x stroke x rod diameter)
 Boom 2–160 mm x 1570 mm x 110 mm **6.3" x 61.8" x 4.3"**
 Arm except 2.4 m **7"10" arm**
 1–185 mm x 1820 mm x 120 mm **7.3" x 71.7" x 4.7"**
 for 2.4 m **7"10" arm**
 1–185 mm x 1590 mm x 120 mm **7.3" x 62.6" x 4.7"**
 Bucket 1–160 mm x 1270 mm x 110 mm **6.3" x 50" x 4.3"**



DRIVES AND BRAKES

Steering control Two levers with pedals
 Drive method Hydrostatic
 Maximum drawbar pull 329 kN **33510 kgf 73,880 lb**
 Gradeability 70%, 35°
 Maximum travel speed: High 5.5 km/h **3.4 mph**
 (Auto-Shift) Mid 4.4 km/h **2.7 mph**
 (Auto-Shift) Low 3.0 km/h **1.9 mph**
 Service brake Hydraulic lock
 Parking brake Mechanical disc brake



SWING SYSTEM

Drive method Hydrostatic
 Swing reduction Planetary gear
 Swing circle lubrication Grease-bathed
 Service brake Hydraulic lock
 Holding brake/Swing lock Mechanical disc brake
 Swing speed 9.0 rpm
 Swing torque 15359 Kg·m **111,059 ft. lbs.**



UNDERCARRIAGE

Center frame X-frame
 Track frame Box-section
 Track type Sealed
 Track adjuster Hydraulic
 Number of shoes (each side) 49
 Number of carrier rollers 2 each side
 Number of track rollers (each side) 8



COOLANT AND LUBRICANT CAPACITY (REFILLING)

Fuel tank 650 ltr **172 U.S. gal**
 Coolant 36.8 ltr **9.7 U.S. gal**
 Engine 38.0 ltr **10.0 U.S. gal**
 Final drive, each side 12.0 ltr **3.2 U.S. gal**
 Swing drive 16.2 ltr **4.3 U.S. gal**
 Hydraulic tank 248 ltr **65.5 U.S. gal**



OPERATING WEIGHT (APPROXIMATE)

Operating weight including 7060 mm **23'2"** one-piece boom, 3380 mm **11'1"** arm, SAE heaped 1.94 m³ **2.54 yd³** bucket, rated capacity of lubricants, coolant, full fuel tank, operator, and standard equipment.

Shoes	PC400LC-7		PC400LC-7 Variable Gauge	
	Operating Weight	Ground Pressure	Operating Weight	Ground Pressure
700 mm 28"	43500 kg 95,901 lb	0.66 kgf/cm ² 9.45 psi	44575 kg 98,271 lb	0.68 kgf/cm ² 9.69 psi
800 mm 31.5"	43950 kg 96,893 lb	0.59 kgf/cm ² 8.35 psi	45025 kg 99,263 lb	0.60 kgf/cm ² 8.56 psi
900 mm 35.5"	44400 kg 97,885 lb	0.53 kgf/cm ² 7.50 psi	45475 kg 100,255 lb	0.54 kgf/cm ² 7.69 psi



WORKING FORCES

Arms	2400 mm 7'10"	2900 mm 9'6"	3380 mm 11'1"	4000 mm 13'1"	4800 mm 15'9"
	SAE rating				
Bucket digging force at Power Max	24600 kgf 54,230 lb	24500 kgf 54,010 lb	24400 kgf 53,790 lb	24400 kgf 53,790 lb	24400 kgf 53,790 lb
	Arm crowd force at Power Max	24600 kgf 54,230 lb	25000 kgf 55,120 lb	20900 kgf 46,080 lb	18800 kgf 41,450 lb
ISO rating					
	Bucket digging force at Power Max	28200 kgf 62,170 lb	28100 kgf 61,950 lb	28000 kgf 61,730 lb	27500 kgf 60,630 lb
Arm crowd force at Power Max	25900 kgf 57,100 lb	26200 kgf 57,760 lb	21800 kgf 48,060 lb	19400 kgf 42,770 lb	17000 kgf 37,500 lb



DIMENSIONS

	Arm	2400 mm	7'10"	2900 mm	9'6"	3380 mm	11'1"	4000 mm	13'1"	4800 mm	15'9"
A	Overall length	11905 mm	39'1"	11995 mm	39'4"	11940 mm	39'2"	11950 mm	38'10"	11830 mm	38'10"
B	Length on ground (transport)	8375 mm	27'6"	7475 mm	24'6"	6705 mm	22'0"	6330 mm	20'9"	6035 mm	20'
C	Overall height (to top of boom)	3850 mm	12'8"	3745 mm	12'3"	3635 mm	11'11"	3885 mm	12'9"	4435 mm	14'7"
D	Overall width	3540 mm	11'7"								
E	Overall height (to top of cab)	3265 mm	10'9"								
F	Ground clearance, counterweight	1320 mm	4'4"								
G	Ground clearance, (minimum)	550 mm	1'10"								
H	Tail swing radius	3645 mm	12'0"								
I	Track length on ground	4350 mm	14'3"								
J	Track length	5355 mm	17'7"								
K	Track gauge	2740 mm	9'0"								
L	Width of crawler	3540 mm	11'7"								
M	Shoe width	800 mm	31.5"								
N	Grouser height	37 mm	1.5"								
O	Machine cab height	2885 mm	9'6"								
P	Machine cab width	2995 mm	9'10"								
Q	Distance, swing center to rear end	3605 mm	11'10"								

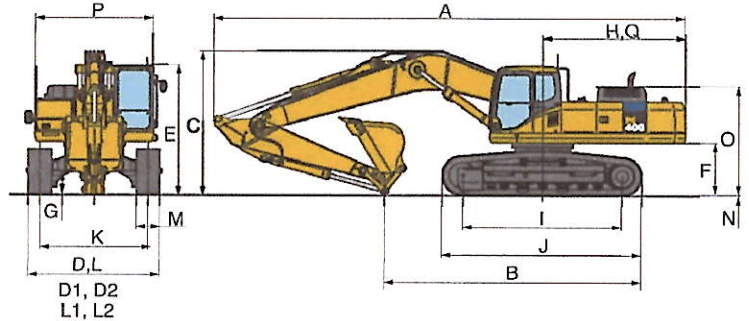

Variable Gauge Transportation Dimension Differences			
D1	Overall width (crawler retracted)	3190 mm	10'6"
D2	Overall width (crawler extended)	3690 mm	12'1"
G	Ground clearance (minimum)	685 mm	2'3"
K	Track gauge (crawler extended)	2890 mm	9'6"
L1	Width of crawler (retracted)	3190 mm	10'6"
L2	Width of crawler (extended)	3690 mm	12'1"
M	Track shoe width	800 mm	31.5"



BACKHOE BUCKET, ARM, AND BOOM COMBINATION

Bucket Type	Bucket			Arms						
	Capacity		Width	Weight		2400 mm 7'10"	2900 mm 9'6"	3380 mm 11'1"	4000 mm 13'1"	4800 mm 15'9"
Komatsu GSK	1.12 m ³	1.47 yd ³	762 mm 30"	1266 kg	2,790 lb	V	V	V	V	V
	1.35 m ³	1.76 yd ³	914 mm 36"	1393 kg	3,072 lb	V	V	V	V	V
	1.64 m ³	2.15 yd ³	1067 mm 42"	1536 kg	3,386 lb	V	V	V	W	X
	1.94 m ³	2.54 yd ³	1219 mm 48"	1646 kg	3,629 lb	V	V	W	X	Y
	2.25 m ³	2.94 yd ³	1372 mm 54"	1790 kg	3,947 lb	W	W	X	Y	Z
	2.55 m ³	3.34 yd ³	1524 mm 60"	1903 kg	4,195 lb	X	X	Y	Z	Z
Komatsu HP	1.12 m ³	1.47 yd ³	762 mm 30"	1508 kg	3,324 lb	V	V	V	V	V
	1.35 m ³	1.76 yd ³	914 mm 36"	1663 kg	3,667 lb	V	V	V	V	W
	1.64 m ³	2.15 yd ³	1067 mm 42"	1835 kg	4,046 lb	V	V	V	W	X
	1.94 m ³	2.54 yd ³	1219 mm 48"	1978 kg	4,360 lb	W	W	X	X	Y
	2.25 m ³	2.94 yd ³	1372 mm 54"	2151 kg	4,741 lb	X	X	Y	Y	Z
	2.55 m ³	3.34 yd ³	1524 mm 60"	2293 kg	5,056 lb	Y	Y	Y	Z	Z
Komatsu HPS	1.12 m ³	1.47 yd ³	762 mm 30"	1632 kg	3,597 lb	V	V	V	V	V
	1.35 m ³	1.76 yd ³	914 mm 36"	1806 kg	3,981 lb	V	V	V	V	W
	1.64 m ³	2.15 yd ³	1067 mm 42"	2003 kg	4,416 lb	V	V	W	X	Y
	1.94 m ³	2.54 yd ³	1219 mm 48"	2172 kg	4,789 lb	W	W	X	Y	Z
	2.25 m ³	2.94 yd ³	1372 mm 54"	2371 kg	5,228 lb	X	X	Y	Z	Z
	2.55 m ³	3.34 yd ³	1524 mm 60"	2540 kg	5,600 lb	Y	Y	Z	Z	Z
Komatsu HPX	1.12 m ³	1.47 yd ³	762 mm 30"	1759 kg	3,877 lb	V	V	V	V	V
	1.35 m ³	1.76 yd ³	914 mm 36"	1933 kg	4,261 lb	V	V	V	V	W
	1.64 m ³	2.15 yd ³	1067 mm 42"	2130 kg	4,696 lb	V	V	W	X	Y
	1.94 m ³	2.54 yd ³	1219 mm 48"	2299 kg	5,069 lb	W	W	X	Y	Z
	2.25 m ³	2.94 yd ³	1372 mm 54"	2498 kg	5,508 lb	X	Y	Y	Z	Z
	2.55 m ³	3.34 yd ³	1524 mm 60"	2667 kg	5,880 lb	Y	Y	Z	Z	Z
			1676 mm 66"	2866 kg	6,319 lb	Z	Z	Z	Z	Z

V – Used with weights up to 3,500 lb/yd³, W – Used with weights up to 3,000 lb/yd³

X – Used with weights up to 2,500 lb/yd³, Y – Used with weights up to 2,000 lb/yd³, Z – Not useable

WORKING RANGES



WORKING RANGE

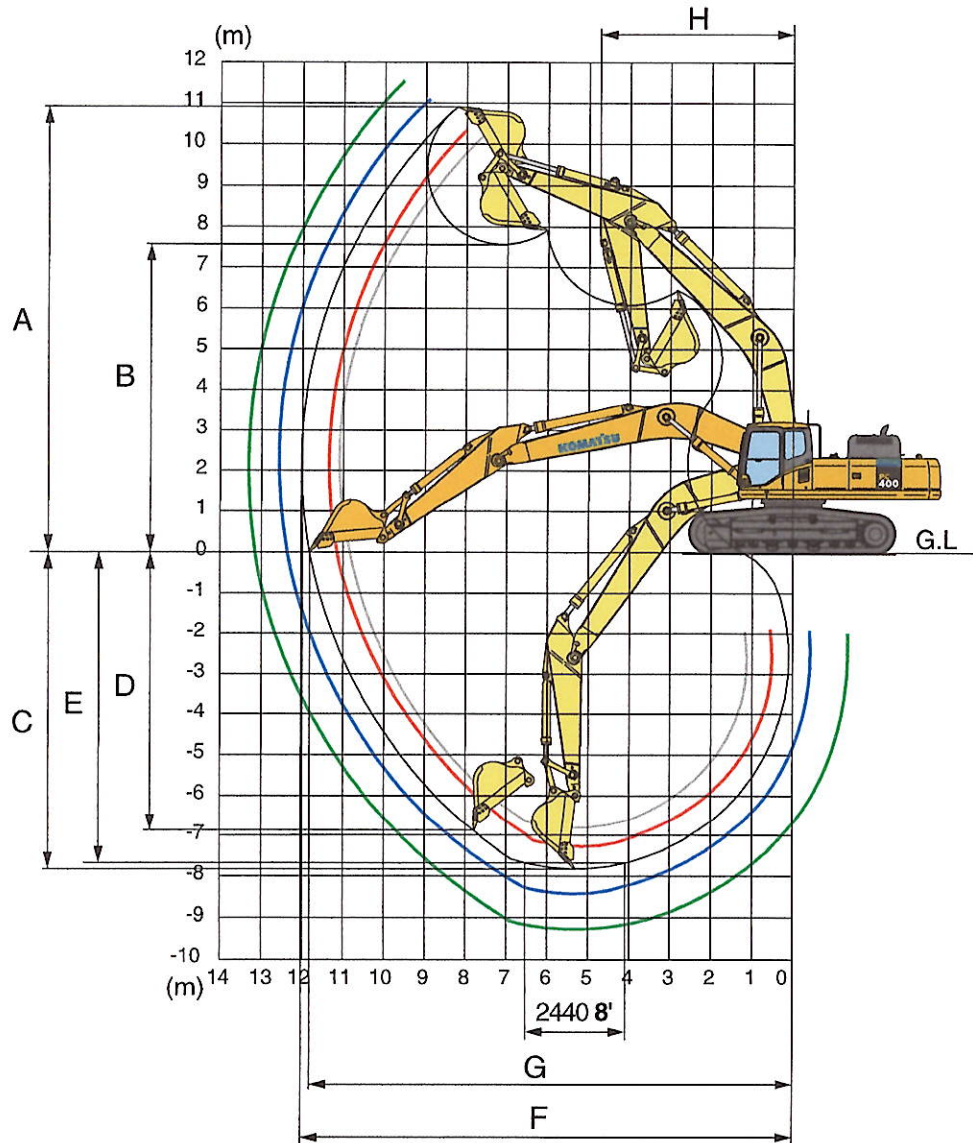

Arm	2400 mm 7'10"	2900 mm 9'6"	3380 mm 11'1"	4000 mm 13'1"	4800 mm 15'9"
A Max. digging height	10310 mm 33'10"	10285 mm 33'9"	10915 mm 35'10"	11025 mm 36'2"	11485 mm 37'8"
B Max. dumping height	7070 mm 23'2"	7080 mm 23'3"	7565 mm 24'10"	7715 mm 25'4"	8145 mm 26'9"
C Max. digging depth	6845 mm 22'6"	7345 mm 24'1"	7820 mm 25'8"	8445 mm 27'8"	9255 mm 30'4"
D Max. vertical wall digging depth	5305 mm 17'5"	5700 mm 18'8"	6870 mm 22'6"	7285 mm 23'11"	8150 mm 26'9"
E Max. digging depth of cut for 8' level	6650 mm 21'10"	7155 mm 23'6"	7680 mm 25'2"	8315 mm 27'3"	9145 mm 30'0"
F Max. digging reach	11080 mm 36'4"	11445 mm 37'7"	12025 mm 39'5"	12565 mm 41'3"	13365 mm 43'10"
G Max. digging reach at ground level	10855 mm 35'7"	11230 mm 36'10"	11820 mm 38'9"	12365 mm 40'7"	13180 mm 43'3"
H Min. swing radius	4835 mm 15'10"	4810 mm 15'9"	4735 mm 15'6"	4800 mm 15'9"	4885 mm 16'0"

LIFTING CAPACITIES



STANDARD TRACK LIFTING CAPACITY

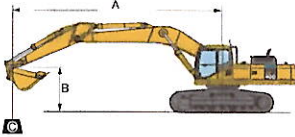

- A: Reach from swing center
- B: Bucket hook height
- C: Lifting capacity
- Cf: Rating over front
- Cs: Rating over side
- ☉: Rating at maximum reach

- Conditions:
- Boom length: 7060 mm 23'2"
 - Bucket: 1.90 m³ 2.49 yd³
 - Bucket weight: 1356 kg 2,990 lb.
 - Lifting mode: On

PC400LC-7		Arm: 2400 mm 7'10"		Shoe: 900 mm 35.5"										Unit: kg lb	
B	A	3.0 m 10'		4.6 m 15'		6.1 m 20'		7.6 m 25'		9.1 m 30'		10.7 m 35'		☉ Maximum	
		Cf	Cs	Cf	Cs	Cf	Cs	Cf	Cs	Cf	Cs	Cf	Cs	Cf	Cs
-7.6 m 25'								*10900 *23,900	8900 19,600					*10850 *23,800	8450 18,500
6.1 m 20'								*11300 *24,800	8800 19,300					*10600 *23,300	6900 15,200
4.6 m 15'				*19400 *42,600	18450 40,600	*14700 *32,300	12100 26,600	*12150 *26,700	8500 18,700	10300 22,700	6250 13,800			10100 22,200	6100 13,400
3.0 m 10'						*16300 *35,900	11200 24,600	*13050 *28,700	8150 17,900	10150 22,300	6100 13,300			9500 20,800	5650 12,400
1.5 m 5'						*17650 *38,800	10850 23,800	*13300 *29,200	7850 17,200	10000 21,900	5900 13,000			9350 20,500	5550 12,100
0.0 m 0'				*17650 *38,800	16200 35,600	*17850 *39,300	10550 23,200	*13050 *28,700	7650 16,700	9850 21,700	5800 12,700			9650 21,100	5700 12,400
-1.5 m -5'				*21950 *48,400	16300 35,800	*17100 *37,700	10450 23,000	*12950 *28,500	7550 16,600					10450 23,000	6150 13,500
-3.0 m -10'	*22900 *50,400	*22900 *50,400	*19300 *42,400	16550 36,400	*15300 *33,700	10600 23,300	*11850 *26,000	7650 16,800						11050 24,300	7200 15,800
-4.6 m -15'			*15000 *33,000	*15000 *33,000	*11650 *25,600	10750 23,700								*10400 *22,900	9600 21,100

PC400LC-7		Arm: 2900 mm 9'6"		Shoe: 900 mm 35.5"										Unit: kg lb	
B	A	3.0 m 10'		4.6 m 15'		6.1 m 20'		7.6 m 25'		9.1 m 30'		10.7 m 35'		☉ Maximum	
		Cf	Cs	Cf	Cs	Cf	Cs	Cf	Cs	Cf	Cs	Cf	Cs	Cf	Cs
-7.6 m 25'								*10500 *22,100	9000 19,800					*9900 *21,700	7600 16,700
6.1 m 20'								*10600 *23,200	8850 19,400	*9750 *21,400	6300 13,800			*9750 *21,400	6300 13,800
4.6 m 15'				*18150 *39,900	*18150 *39,900	*13800 *30,300	12200 26,800	*11500 *25,200	8500 18,700	*10100 *22,200	6200 13,650			9350 20,500	5550 12,200
3.0 m 10'				*22050 *48,600	17500 38,500	*15700 *34,500	11450 25,100	*12500 *27,500	8100 17,800	10100 22,200	6000 13,200			8800 19,300	5200 11,300
1.5 m 5'				*21750 *47,800	16350 35,900	*17100 *37,600	10800 23,700	*13200 *29,000	7750 17,000	9900 21,700	5800 12,700			8650 18,900	5050 11,100
0.0 m 0'				*23500 *51,800	15950 35,1000	*17650 *38,800	10400 22,800	*12990 *28,400	7500 16,400	9700 21,400	5650 12,450			8850 19,400	5150 11,300
-1.5 m -5'	*16600 *36,500	*16600 *36,500	*22700 *49,900	15950 35,100	*17250 *37,900	10250 22,500	*12800 *28,100	7350 16,200	9650 21,200	5600 12,300				9550 21,000	5550 12,200
-3.0 m -10'	*25500 *56,200	*25500 *56,200	*20350 *44,800	16150 35,600	*15800 *34,800	10300 22,600	*12300 *27,100	7400 16,300						*10600 *23,300	6400 14,000
-4.6 m -15'	*20550 *45,300	*20550 *45,300	*16600 *36,500	*16600 *36,500	*13000 *28,600	10600 23,200								*10350 *22,700	8250 18,100

Ratings are based on ISO Standard No. 10567. Rated loads do not exceed 87% of hydraulic lift capacity or 75% of tipping load.
 *Load is limited by hydraulic capacity rather than tipping.

PC400LC-7 HYDRAULIC EXCAVATOR

LIFTING CAPACITIES



STANDARD TRACK LIFTING CAPACITY *continued*

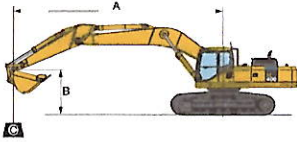

- A: Reach from swing center
- B: Bucket hook height
- C: Lifting capacity
- Cf: Rating over front
- Cs: Rating over side
- ⊗: Rating at maximum reach

- Conditions:
- Boom length: 7060 mm 23'2"
 - Bucket: 1.90 m³ 2.49 yd³
 - Bucket weight: 1356 kg 2,990 lb.
 - Lifting mode: On

PC400LC-7		Arm: 3380 mm 11'1"				Shoe: 900 mm 35.5"				Unit: kg lb					
B	A	3.0 m 10'		4.6 m 15'		6.1 m 20'		7.6 m 25'		9.1 m 30'		10.7 m 35'		⊗ Maximum	
		Cf	Cs	Cf	Cs	Cf	Cs	Cf	Cs	Cf	Cs	Cf	Cs	Cf	Cs
-7.6 m 25'														*6450 *14,200	*6450 *14,100
6.1 m 20'								*10100 *22,100	9050 19,800	*9350 *20,500	6500 14,200			*6400 *14,100	5600 12,300
4.6 m 15'						*13100 *28,800	12500 27,500	*11050 *24,300	8700 19,100	*9800 *21,500	6350 13,900			*6550 *14,400	5050 11,000
3.0 m 10'				*21000 *46,300	18150 40,000	*15150 *33,300	11750 25,800	*12200 *26,800	8300 18,200	10200 22,400	6150 13,400			*6950 *15,300	4700 10,300
1.5 m 5'				*23750 *52,300	16850 37,000	*16800 *37,000	11050 24,200	*13150 *28,900	7900 17,300	10000 21,900	5900 13,000			*7550 *16,500	4600 10,100
0.0 m 0'				*22750 *50,100	16250 35,700	*17650 *38,900	10600 23,200	13050 28,700	7600 16,700	9800 21,500	5750 12,600			8050 17,700	4700 10,300
-1.5 m -5'		*14500 *31,900	*14500 *31,900	*23550 *51,900	16100 35,400	*17600 *38,700	10350 22,800	12850 28,300	7450 16,300	9700 21,300	5650 12,400			8600 18,900	5000 11,000
-3.0 m -10'		*21250 *46,800	*21250 *46,800	*21600 *47,500	16200 35,700	*16500 *36,300	10350 22,800	12850 28,200	7450 16,300	9750 21,400	5700 12,500			9700 21,300	5700 12,550
-4.6 m -15'		*23850 *52,500	*23850 *52,500	*18300 *40,300	16550 36,400	*14200 *31,200	10550 23,200	*10700 *23,600	7600 16,700					*9600 *21,100	7000 15,300
-6.1 m -20'				*12850 *28,300	*12850 *28,300	*9600 *21,150	*9600 *21,150							*8600 *18,900	*8600 *18,900

PC400LC-7		Arm: 4000 mm 13'1"				Shoe: 900 mm 35.5"				Unit: kg lb					
B	A	3.0 m 10'		4.6 m 15'		6.1 m 20'		7.6 m 25'		9.1 m 30'		10.7 m 35'		⊗ Maximum	
		Cf	Cs	Cf	Cs	Cf	Cs	Cf	Cs	Cf	Cs	Cf	Cs	Cf	Cs
-7.6 m 25'										*7950 *17,500	6700 14,700			*5500 *12,100	*5500 *12,100
6.1 m 20'										*8700 *19,100	6600 14,500			*5500 *12,100	5100 11,100
4.6 m 15'								*10300 *22,600	8800 19,300	*9200 *20,200	6400 14,100	*7000 *15,300	4750 10,400	*5600 *12,300	4600 10,000
3.0 m 10'				*19000 *41,800	18450 40,600	*14150 *31,100	11900 26,200	*11500 *25,300	8350 18,300	*9900 *21,700	6150 13,500	7900 17,300	4650 10,200	*5900 *12,900	4300 9,400
1.5 m 5'				*22600 *49,700	17100 37,700	*16050 *35,300	11150 24,500	*12600 *27,700	7900 17,400	1000 21,900	5900 12,900	7750 17,000	4500 9,900	*6400 *14,000	4200 9,200
0.0 m 0'		*9700 *21,300	*9700 *21,300	*24100 *53,000	16250 35,800	*17250 *38,000	10550 23,200	13000 28,600	7550 16,600	9750 21,400	5700 12,500	7650 16,700	4400 9,600	*7100 *15,600	4250 9,300
-1.5 m -5'		*14050 *30,900	*14050 *30,900	*23950 *52,700	15950 35,000	*17550 *38,600	10250 22,500	12750 28,000	7350 16,100	9600 21,100	5600 12,200			7800 17,100	4500 9,800
-3.0 m -10'		*19400 *42,700	*19400 *42,700	*22550 *49,600	15950 35,000	*16900 *37,200	10150 22,300	12650 27,900	7300 16,000	9600 21,150	5600 12,100			8650 19,000	5000 11,000
-4.6 m -15'		*26200 *57,700	*26200 *57,700	*19850 *43,600	16150 35,600	*15150 *33,300	10250 22,600	*11700 *25,700	7350 16,100					*9250 *20,300	6000 13,100
-6.1 m -20'		*20150 *44,300	*20150 *44,300	*15350 *33,800	*15350 *33,800	*11700 *25,700	10600 23,300							*8850 *19,400	8100 17,800

Ratings are based on ISO Standard No. 10567. Rated loads do not exceed 87% of hydraulic lift capacity or 75% of tipping load.
*Load is limited by hydraulic capacity rather than tipping.



STANDARD TRACK LIFTING CAPACITY *continued*

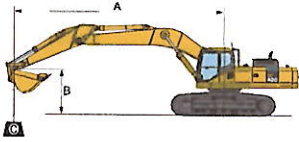

- A: Reach from swing center
- B: Bucket hook height
- C: Lifting capacity
- Cf: Rating over front
- Cs: Rating over side
- ⊗: Rating at maximum reach

- Conditions:
- Boom length: 7060 mm 23'2"
 - Bucket: 1.90 m³ 2.49 yd³
 - Bucket weight: 1356 kg 2,990 lb.
 - Lifting mode: On

PC400LC-7		Arm: 4800 mm 15'9"				Shoe: 900 mm 35.5"				Unit: kg lb					
B	A	3.0 m 10'		4.6 m 15'		6.1 m 20'		7.6 m 25'		9.1 m 30'		10.7 m 35'		⊗ Maximum	
		Cf	Cs	Cf	Cs	Cf	Cs	Cf	Cs	Cf	Cs	Cf	Cs	Cf	Cs
-7.6 m 25'														*4300 *9,400	*4300 *9,400
6.1 m 20'										*7850 *17,200	6800 14,900	*6700 *14,700	5000 10,900	*4300 *9,400	*4300 *9,400
4.6 m 15'										*8450 *18,600	6550 14,400	*7900 *17,300	4900 10,700	*4350 *9,500	4000 8,700
3.0 m 10'						*12750 *28,000	12300 27,000	*10600 *23,200	8550 18,800	*9200 *20,200	6250 13,700	8000 17,500	4700 10,300	*4550 *10,000	3750 8,200
1.5 m 5'				*20800 *45,700	17700 39,000	*14950 *32,900	11400 25,000	*11850 *26,100	8050 17,700	*1000 *21,900	5950 13,100	7800 17,100	4550 9,900	*4900 *10,700	3650 8,000
0.0 m 0'		*10450 *22,900	*10450 *22,900	*23250 *51,200	16500 36,400	*16550 *36,500	10700 23,500	*12900 *28,300	7600 16,700	9800 21,500	5700 12,500	7600 16,700	4400 9,600	*5350 *11,700	3700 8,100
-1.5 m -5'		*13100 *28,800	*13100 *28,800	*24000 *52,800	15900 35,000	*17350 *38,100	10250 22,500	12750 28,000	7300 16,100	9550 21,050	5500 12,100	7500 16,500	4300 9,400	*6100 *13,300	3900 8,500
-3.0 m -10'		*17050 *37,500	*17050 *37,500	*23350 *51,400	15700 34,500	*17200 *37,900	10050 22,000	12550 27,600	7150 15,700	9450 20,800	5400 11,900	7500 16,400	4250 9,300	*7200 *15,800	4250 9,300
-4.6 m -15'		*22250 *49,000	*22250 *49,000	*21450 *47,200	15800 34,800	*16100 *35,400	10050 22,100	*12500 *27,400	7150 15,700	9500 20,900	5450 12,000			*8500 *18,700	4950 10,800
-6.1 m -20'		*24850 *54,700	*24850 *54,700	*18000 *39,600	16150 35,500	*13650 *30,000	10250 22,500	*10300 *22,700	7350 16,200					*8400 *18,400	6250 13,700
-7.6 m -25'				*12200 *26,800	*12200 *26,800	*8850 *19,500	*8850 *19,500							*7550 *16,650	*7550 *16,650

Ratings are based on ISO Standard No. 10567. Rated loads do not exceed 87% of hydraulic lift capacity or 75% of tipping load.
*Load is limited by hydraulic capacity rather than tipping.

PC400LC-7 HYDRAULIC EXCAVATOR

LIFTING CAPACITIES



VARIABLE GAUGE LIFTING CAPACITY

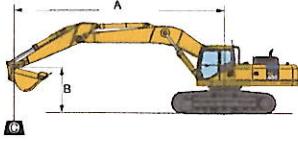

- A: Reach from swing center
- B: Bucket hook height
- C: Lifting capacity
- Cf: Rating over front
- Cs: Rating over side
- ⊗: Rating at maximum reach

Conditions:

- Boom length: 7060 mm 23'2"
- Bucket: 1.9 m³ 2.49 yd³
- Bucket weight: 1356 kg 2,990 lb.
- Lifting mode: On

PC400LC-7 VTG		Arm: 2400 mm 7'10"				Shoe: 900 mm 35.5"				Unit: kg lb					
B	A	3.0 m 10'		4.6 m 15'		6.1 m 20'		7.6 m 25'		9.1 m 30'		10.7 m 35'		⊗ Maximum	
		Cf	Cs	Cf	Cs	Cf	Cs	Cf	Cs	Cf	Cs	Cf	Cs	Cf	Cs
-7.6 m 25'								*10900 *23,900	9650 21,200					*10850 *23,800	9150 20,100
6.1 m 20'								*11300 *24,800	9500 20,900					*10600 *23,400	7500 16,500
4.6 m 15'				*19400 *42,600	*19400 *42,600	*14700 *32,300	13150 28,900	*12150 *26,700	9250 20,300	10550 23,200	6800 14,900			10350 22,800	6650 14,650
3.0 m 10'						*16300 *35,900	11200 26,800	*13050 *28,700	8850 19,500	10400 22,900	6600 14,550			9750 21,400	6200 13,600
1.5 m 5'						*17650 *38,800	11850 26,000	13600 29,900	8550 18,800	10250 22,500	6450 14,200			9600 21,100	6050 13,300
0.0 m 0'				*17650 *38,800	*17650 *38,800	*17850 *39,300	11550 25,300	13400 29,400	8350 18,400	10100 22,200	6350 13,900			9900 21,700	6200 13,600
-1.5 m -5'				*21950 *48,400	17900 39,400	*17100 *37,700	11450 25,200	13300 29,200	8250 18,100					10750 23,600	6750 14,800
-3.0 m -10'		*22900 *50,400	*22900 *50,400	*19300 *42,400	18200 40,000	*15300 *33,700	11600 25,400	*11850 *26,000	8350 18,400					*11050 *24,300	7900 17,300
-4.6 m -15'				*15000 *33,000	*15000 *33,000	*11650 *25,600	*11650 *25,600							*10400 *22,900	*10400 *22,900

PC400LC-7 VTG		Arm: 2900 mm 9'6"				Shoe: 900 mm 35.5"				Unit: kg lb					
B	A	3.0 m 10'		4.6 m 15'		6.1 m 20'		7.6 m 25'		9.1 m 30'		10.7 m 35'		⊗ Maximum	
		Cf	Cs	Cf	Cs	Cf	Cs	Cf	Cs	Cf	Cs	Cf	Cs	Cf	Cs
-7.6 m 25'								*10050 *22,100	9750 21,400					*9900 *21,700	8250 18,100
6.1 m 20'								*10600 *23,200	9550 21,050	*9750 *21,400	6850 15,100			*9750 *21,400	6850 15,000
4.6 m 15'				*18150 *39,900	*18150 *39,900	*13800 *30,300	13250 29,100	*11500 *25,200	9200 20,300	*10100 *22,200	6750 14,800			9550 21,050	6100 13,300
3.0 m 10'				*22050 *48,600	19150 42,200	*15700 *34,500	12450 27,300	*12500 *27,500	8800 19,400	10350 22,700	6550 14,400			9000 19,800	5650 12,400
1.5 m 5'				*21750 *47,800	17950 39,500	*17100 *37,600	11750 25,900	*13350 *29,300	8450 18,600	10150 22,300	6350 13,900			8850 19,500	5550 12,100
0.0 m 0'				*23500 *51,800	17550 38,700	*17650 *38,800	11350 25,000	13250 29,100	8200 18,000	1000 21,900	6200 13,600			9100 20,000	5650 12,400
-1.5 m -5'		*16600 *36,500	*16600 *36,500	*22700 *49,900	17550 38,600	*17250 *37,900	11250 24,700	13100 28,800	8050 17,700	9950 21,800	6150 13,500			9800 21,500	6100 13,300
-3.0 m -10'		*25500 *56,200	*25500 *56,200	*20350 *44,800	17800 39,100	*15800 *34,800	11300 24,800	*12300 *27,100	8100 17,800					*10600 *23,350	7000 15,400
-4.6 m -15'		*20550 *45,300	*20550 *45,300	*16600 *36,500	*16600 *36,500	*13000 *28,600	11550 25,400							*10350 *22,700	9000 19,700

Ratings are based on ISO Standard No. 10567. Rated loads do not exceed 87% of hydraulic lift capacity or 75% of tipping load.
*Load is limited by hydraulic capacity rather than tipping.

PC400LC-7 VTG		Arm: 3380 mm 11'1"				Shoe: 900 mm 35.5"				Unit: kg lb				
B \ A	3.0 m 10'		4.6 m 15'		6.1 m 20'		7.6 m 25'		9.1 m 30'		10.7 m 35'		⊕ Maximum	
	Cf	Cs	Cf	Cs	Cf	Cs	Cf	Cs	Cf	Cs	Cf	Cs	Cf	Cs
-7.6 m 25'													*6450	*6450
6.1 m 20'							*10100	9750	*9350	7050			*6400	6100
4.6 m 15'					*13100	*13100	*11050	9400	*9800	6900			*6550	5500
3.0 m 10'			*21000	19850	*15150	12750	*12200	9000	*10400	6700			*6950	5200
1.5 m 5'			*23750	18500	*16800	12050	*13150	8600	*10250	6450			*7550	5050
0.0 m 0'			*22750	17850	*17650	11550	13350	8300	10050	6300			8300	5150
-1.5 m -5'	*14500	*14500	*23550	17750	*17600	11350	13200	8150	9950	6200			8850	5500
-3.0 m -10'	*21250	*21250	*21600	17850	*16500	11350	*12850	8150	*9850	6250			*9800	6200
-4.6 m -15'	*23850	*23850	*18300	18200	*14200	11550	*10700	8300					*9600	7650
-6.1 m -20'			*12850	*12850	*9600	*9600							*8600	*8600

PC400LC-7 VTG		Arm: 4000 mm 13'1"				Shoe: 900 mm 35.5"				Unit: kg lb				
B \ A	3.0 m 10'		4.6 m 15'		6.1 m 20'		7.6 m 25'		9.1 m 30'		10.7 m 35'		⊕ Maximum	
	Cf	Cs	Cf	Cs	Cf	Cs	Cf	Cs	Cf	Cs	Cf	Cs	Cf	Cs
-7.6 m 25'									*7950	7200			*5450	*5450
6.1 m 20'									*8650	7100			*5450	*5450
4.6 m 15'							*10250	9500	*9200	6900	*6950	5200	*5500	5000
3.0 m 10'			*189850	*18950	*14100	12900	*11450	9050	*9850	6650	8050	5050	*5850	4700
1.5 m 5'			*22550	18750	*16000	12100	*12600	8600	10200	6400	7950	4900	*6350	4600
0.0 m 0'	*9700	*9700	*24050	17850	*17200	11500	13300	8250	10000	6200	7800	4800	*7050	4650
-1.5 m -5'	*14000	*14000	*23900	17500	*17500	11200	13050	8000	9850	6050			8000	4900
-3.0 m -10'	*19350	*19350	*22550	17500	*16850	11100	12950	7950	9800	6050			8850	5450
-4.6 m -15'	*26150	*26150	*19800	17750	*15100	11200	*11650	8000					*9200	6550
-6.1 m -20'	*20100	*20100	*15300	*15300	*11650	11550							*8800	*8800

PC400LC-7 VTG		Arm: 4800 mm 15'9"				Shoe: 900 mm 35.5"				Unit: kg lb				
B \ A	3.0 m 10'		4.6 m 15'		6.1 m 20'		7.6 m 25'		9.1 m 30'		10.7 m 35'		⊕ Maximum	
	Cf	Cs	Cf	Cs	Cf	Cs	Cf	Cs	Cf	Cs	Cf	Cs	Cf	Cs
-7.6 m 25'													*4300	*4300
6.1 m 20'									*7800	7300	*6650	5400	*4250	*4250
4.6 m 15'									*8400	7050	*7850	5300	*4350	*4350
3.0 m 10'					*12700	*12700	*10550	9250	*9200	6800	8150	5150	*4500	4100
1.5 m 5'			*20750	19350	*14900	12350	*11800	8700	*9950	6500	7950	4950	*4850	4000
0.0 m 0'	*10400	*10400	*23200	18100	*16500	11650	*12850	8300	10000	6200	7800	4800	*5300	4050
-1.5 m -5'	*13050	*13050	*23950	17500	*17300	11200	13050	8000	9800	6000	7700	4700	*6050	4250
-3.0 m -10'	*17000	*17000	*23300	17300	*17150	11000	12850	7850	9700	5950	*7500	4650	*7150	4650
-4.6 m -15'	*22200	*22200	*21400	17400	*16050	11000	*12450	7800	*9650	5950			*8450	5400
-6.1 m -20'	*24800	*24800	*17950	17750	*13600	11200	*10300	8000					*8350	6850
-7.6 m -25'			*12150	*12150	*8850	*8850							*7500	*7500

Ratings are based on ISO Standard No. 10567. Rated loads do not exceed 87% of hydraulic lift capacity or 75% of tipping load.
 *Load is limited by hydraulic capacity rather than tipping.



STANDARD EQUIPMENT

- Additional fuel filter with water separator
- Automatic air conditioner with defroster, hot & cool box
- Alternator, 50 Ampere, 24V
- Auto-decel
- Automatic engine warm-up system
- Automatic de-aeration system for fuel line
- Batteries, large capacity 140 Ah/2 x 12V
- Boom and arm holding valves
- Cab, capable OPG (FOG) with optional bolt-on top guard, damper mounted
- Counterweight, 9500 kg **20,943 lb**
- Dry type air cleaner, double element
- Electric horn
- EMMS monitoring system
- Engine, Komatsu SAA6D125E-5
- Engine overheat prevention system
- Fan guard structure
- Foot plates, slip resistant
- Frame deck guards, revolving
- Frame undercovers, revolving
- Hydraulic filters, high pressure, in-line
- Hydraulic track adjusters (each side)
- KOMTRAX
- Long lubricating intervals for implement bushings
- Monitor panel, full color, multi-function
- Power maximizing system
- PPC hydraulic control system
- Radiator & oil cooler dust proof net
- Rear view mirror, RH/LH
- Seat belt, retractable 76 mm **3"**
- Seat, suspension
- Service valve
- Starting motor, 11 kW
- Suction fan
- Track guiding guard, center section
- Track roller, 8 each side
- Track shoe
 - 700 mm **28"** triple grouser
- Travel alarm
- Two settings for boom
- Working light, 2 (boom and RH)
- Working mode selection system



OPTIONAL EQUIPMENT

- Arms
 - 2400 mm **7'10"** arm assembly
 - 2900 mm **9'6"** arm assembly
 - 3380 mm **11'1"** arm assembly
 - 3380 mm **11'1"** w/one actuator piping
 - 4000 mm **13'1"** arm assembly
 - 4800 mm **15'9"** arm assembly
- Bolt-on top guard, (Operator Protective Guards level 2 (FOG))
- Boom
 - 7060 mm **23'2"**
 - 7060 mm **23'2"** w/one actuator piping
- Cab accessories
 - Rain visor
 - Sun visor
- Cab front guard
 - Full height guard
 - Half height guard
- Converter, 12V
- Counterweight removal device
- Frame undercovers, revolving, heavy-duty
- Hydraulic control unit
- Pattern change valve
- Shoes, triple grouser shoes
 - 800 mm **31.5"**
 - 900 mm **35.5"**
- Straight travel pedal
- Suspension seat, air-ride
- Track roller guards (full length)
- Track frame undercover
- Variable gauge track frame
- Working light, additional front



ATTACHMENT OPTIONS

- Genesis demolition tools
 - Concrete cracker
 - Hydraulic concrete processor
 - Hydraulic quick coupler
 - Linkage shear
 - Mechanical processor
 - Quick release mounting pad
 - Severe-duty grapple
- JRB Couplers (Smart-Loc, Roto-Loc)
 - Boom cylinder guards
 - Swinger buckets
 - Top window guard (wire mesh)
 - Vandal protection guards
 - Window guards (Lexan®, wire mesh)
- Komatsu buckets
- Komatsu breakers
- Komatsu plate compactors
- Lincoln autolube systems
- PSM thumbs

For a complete list of available attachments, please contact your local Komatsu distributor.

AESS695-02

©2006 Komatsu Printed in USA

DK03(7.5M) C

03/06(EV-2)

KOMATSU®



KOMATSU®

PC450-8 PC450LC-8

PC
450

HORSEPOWER

Gross: 270 kW 362 HP / 1900 min⁻¹
Net: 257 kW 345 HP / 1900 min⁻¹

OPERATING WEIGHT

PC450-8: 43320 – 43740 kg
PC450LC-8: 44320 – 44770 kg

BUCKET CAPACITY

1.30 – 2.80 m³



Photos may include optional equipment.

WALK-AROUND





Quarry Cab

Strengthened
Revolving
Frame with
Deck Guard

Full Roller Guards and
Double-flange Track
Rollers

PRODUCTIVITY, ECOLOGY & ECONOMY

- | Low Fuel Consumption by Total Control of the Engine, Hydraulic and Electronic System
- | Low Emission Engine and Low Operation Noise
- | Excellent Machine Stability
- | Large Digging Force
- | Two-mode Setting for Boom
- | Variable Track Gauge (Optional)

COMFORT & SAFETY

- | Large Comfortable Cab
- | ROPS Cab (ISO 12117-2)
- | Automatic Air Conditioner (A/C) (Optional)
- | Rear View Monitor System (Optional)

* Information and Communication Technology

ICT* & KOMTRAX

- | Large Multi-lingual Liquid Crystal Display (LCD) Monitor
- | Equipment Management Monitoring System
- | KOMTRAX

MAINTENANCE & RELIABILITY

- | Easy Maintenance
- | Excellent Reliability and Durability



	PC450-8	PC450LC-8
HORSEPOWER	Gross: 270 kW 362 HP / 1900 min ⁻¹	270 kW 362 HP / 1900 min ⁻¹
	Net: 257 kW 345 HP / 1900 min ⁻¹	257 kW 345 HP / 1900 min ⁻¹
OPERATING WEIGHT	43320 – 43740 kg	44320 – 44770 kg
BUCKET CAPACITY	1.30 – 2.80 m ³	1.30 – 2.80 m ³

PRODUCTIVITY, ECOLOGY & ECONOMY

Komatsu Technology

Komatsu develops and produces all major components, such as engines, electronics and hydraulic components, in house. With this "Komatsu Technology" and adding customer feedback, Komatsu is achieving great advancements in technology. To achieve both high levels of productivity and economical performance, Komatsu has developed the main components with a total control system. The result is a new generation of high performance and environment friendly excavators.

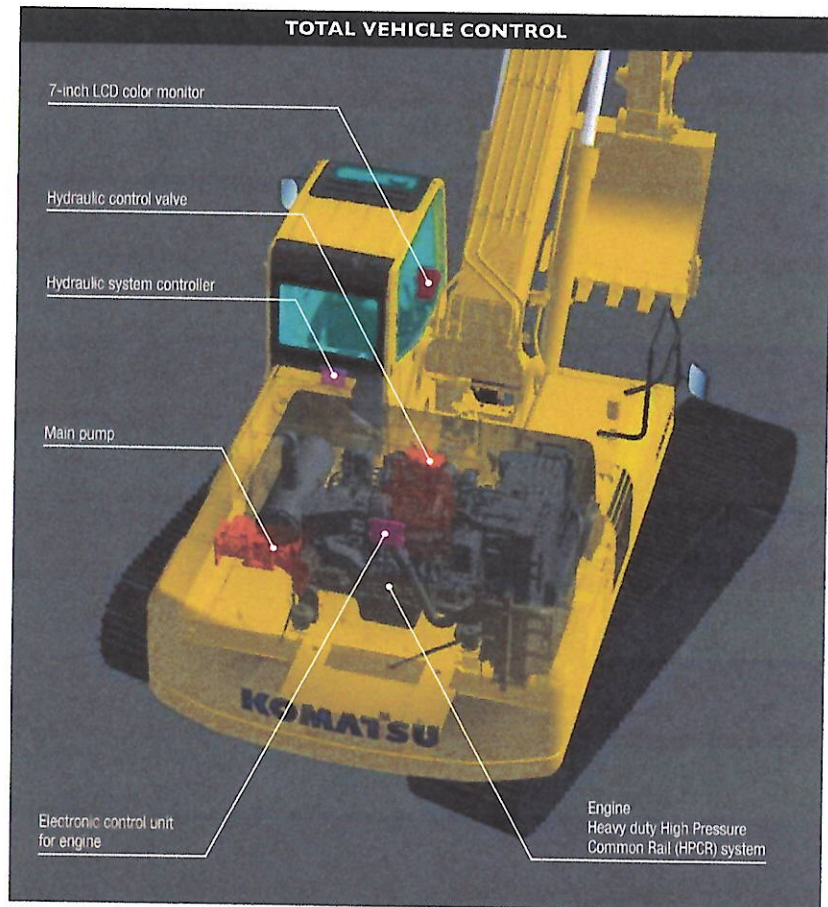

Environment-friendly Clean Engine

The PC450-8 gets its exceptional power and work capacity from a Komatsu SAA6D125E-5 engine. Output is 257 kW 345 HP, providing increased hydraulic power and improved fuel efficiency. Komatsu SAA6D125E-5 engine is U.S. EPA Tier 3 and EU Stage 3A emissions certified with NOx emission reduced by 40%. The SAA6D125E-5 engine adopts the electronically controlled heavy duty High Pressure Common Rail (HPCR) fuel injection system and cooled Exhaust Gas Recirculation (EGR) system with electronically controlled bypass-assist type venturi.



Low Operation Noise

Enables a low noise operation using the low-noise engine and methods to cut noise at source. Ambient noise meets the EU Stage 2 noise regulation.

Excellent Machine Stability

Large counterweight offers superior machine stability and balance.

Idling Caution

To prevent unnecessary fuel consumption, an idling caution is displayed on the monitor, if the engine idles for 5 minutes or more.



ECO Gauge that Assists Energy-saving Operations

Equipped with the ECO gauge that can be recognized at a glance on the right of the multi-function color monitor for environment-friendly energy-saving operations. Allows focus on operation in the green range with reduced CO₂ emissions and efficient fuel consumption.

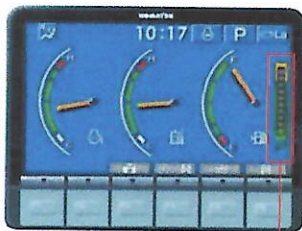

ECO gauge

Working Modes Selectable

The PC450-8 excavator is equipped with five working modes (P, E, L, B and ATT mode). Each mode is designed to match engine speed and pump output to the application. This provides the flexibility to match equipment performance to the job at hand.



Working Mode	Application	Advantage
P	Power mode	<ul style="list-style-type: none"> • Maximum production/power • Fast cycle times
E	Economy mode	<ul style="list-style-type: none"> • Good cycle times • Better fuel economy
L	Lifting mode	<ul style="list-style-type: none"> • Suitable attachment speed • Lifting capacity is increased 7% by raising hydraulic pressure.
B	Breaker mode	<ul style="list-style-type: none"> • Optimum engine rpm, hydraulic flow
ATT	Attachment mode	<ul style="list-style-type: none"> • Optimum engine rpm, hydraulic flow, 2 way

Variable Track Gauge (Optional)

- Lateral stability is significantly improved when operating with the gauge extended.
- Lateral stability is increased by 30% (Compared with the fixed gauge version).
- With trackframes retracted, overall width complies with many local transportation regulations.

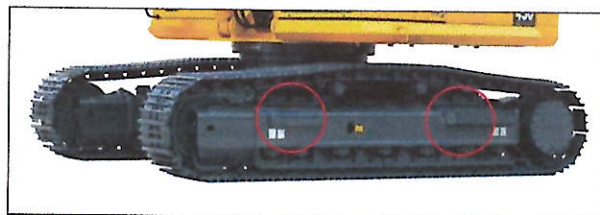

Large Digging Force

When press the left knob switch which is called the one-touch power max. switch and when it is kept pressed, this function temporarily increases digging force for 8.5 seconds of operation.

Maximum arm crowd force (ISO 6015):

218 kN (22.2 t) ➔ **233 kN (23.8 t)** **7% UP**
(With Power Max.)

Maximum bucket digging force (ISO 6015):

259 kN (26.4 t) ➔ **278 kN (28.3 t)** **7% UP**
(With Power Max.)

Measured with Power Max. function, 3380 mm arm and ISO 6015 rating.

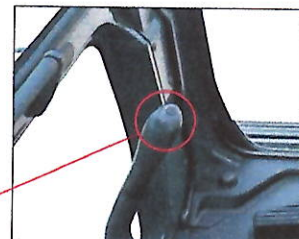

One-touch power max. switch

Smooth Loading Operation

Two return hoses improve hydraulic performance. In the arm out function, a portion of the oil is returned directly to the tank providing smooth operation.

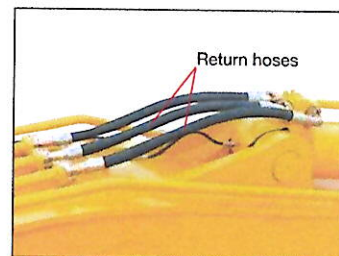

Return hoses

Two-mode Setting for Boom

Smooth mode provides easy operation for gathering blasted rock or scraping down operation. When maximum digging force is needed, switch to Power mode for more effective excavating.

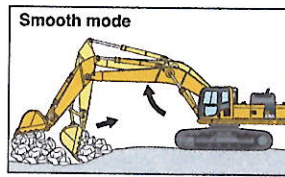

Boom floats upward, reducing lifting of machine front. This facilitates gathering blasted rock and scraping down operations.

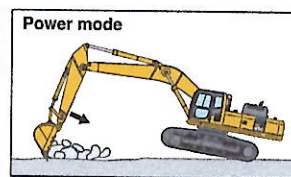

Boom pushing force is increased, ditch digging and box digging operation on hard ground are improved.

COMFORT



Low Cab Noise

The newly-designed cab is highly rigid and has excellent sound absorption ability. Thorough improvement of noise source reduction and use of low noise engine, hydraulic equipment, and air conditioner allows this machine to generate a low level of noise.

Low Vibration with Cab Damper Mounting

PC450-8 uses viscous damper mounting for cab that incorporates longer stroke and the addition of a spring. The new cab damper mounting combined with high rigidity deck aids vibration reduction at operator seat.

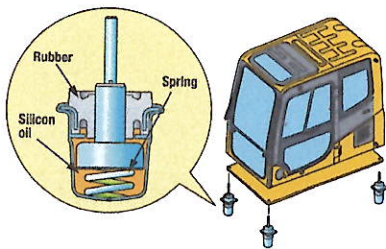

Wide Newly-designed Cab

Newly-designed wide spacious cab includes seat with reclining backrest. The seat height and longitudinal inclination are easily adjusted using a pull-up lever. You can set the appropriate operational posture of armrest together with the console. Reclining the seat further enables you to place it into the fully flat state with the headrest attached.



Pressurized Cab

Optional air conditioner (A/C), air filter and a higher internal air pressure minimize external dust from entering the cab.

Automatic Air Conditioner (A/C) (Optional)

Enables you to easily and precisely set cab atmosphere with the instruments on the large LCD. The bi-level control function keeps the operator's head and feet cool and warm respectively. This improved air flow function keeps the inside of the cab comfortable throughout the year. Defroster function keeps front glass clear.

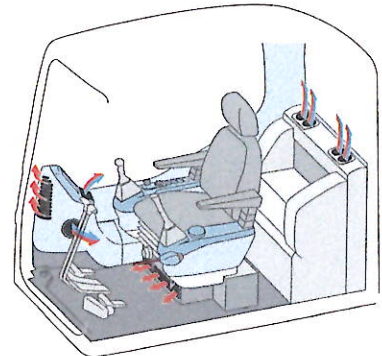

SAFETY

ROPS Cab

The machine is equipped with a ROPS cab that conforms to ISO 12117-2 for excavators as standard equipment. The ROPS cab has high shock-absorption performance, featuring excellent durability and impact strength. It also satisfies the requirements of OPG top guard level 1 (ISO 10262) for falling objects. Combined with the retractable seat belt, The ROPS cab protects the operator in case of tipping over and against falling objects.

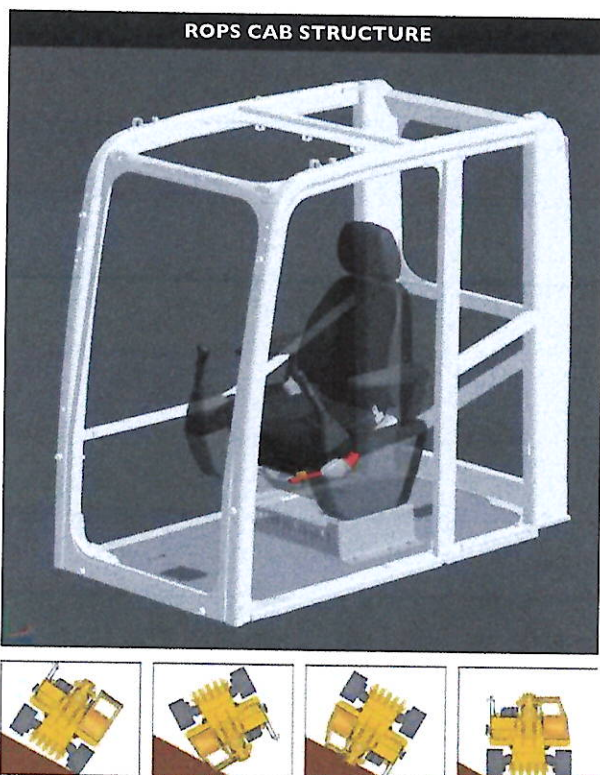

Slip-resistant Plates

Highly durable slip-resistant plates maintain superior traction performance for the long term.

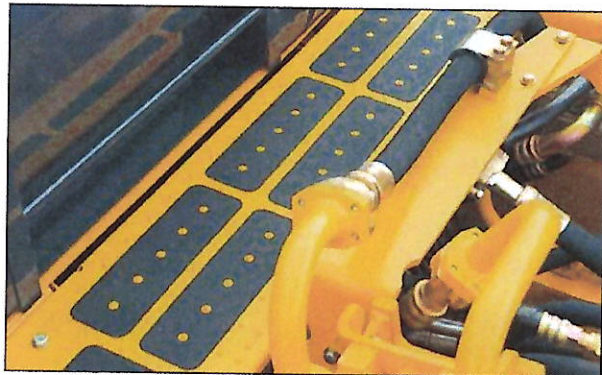

Lock Lever

Locks the hydraulic pressure to prevent unintentional movement. Neutral start function allows machine to be started only in lock position.



Rear View Monitor System (Optional)

The operator can view the rear of the machine with a color monitor screen.



Rear view image on monitor

Pump/Engine Room Partition

Pump/engine room partition prevents oil from spraying onto the engine if a hydraulic hose should fail.



Thermal and Fan Guards

Thermal and fan guards are placed around high-temperature parts of the engine and fan drive.

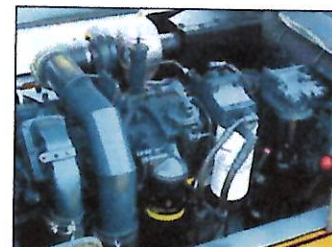

Large Serrated Steps and Handrail

Large serrated steps



Large handrail



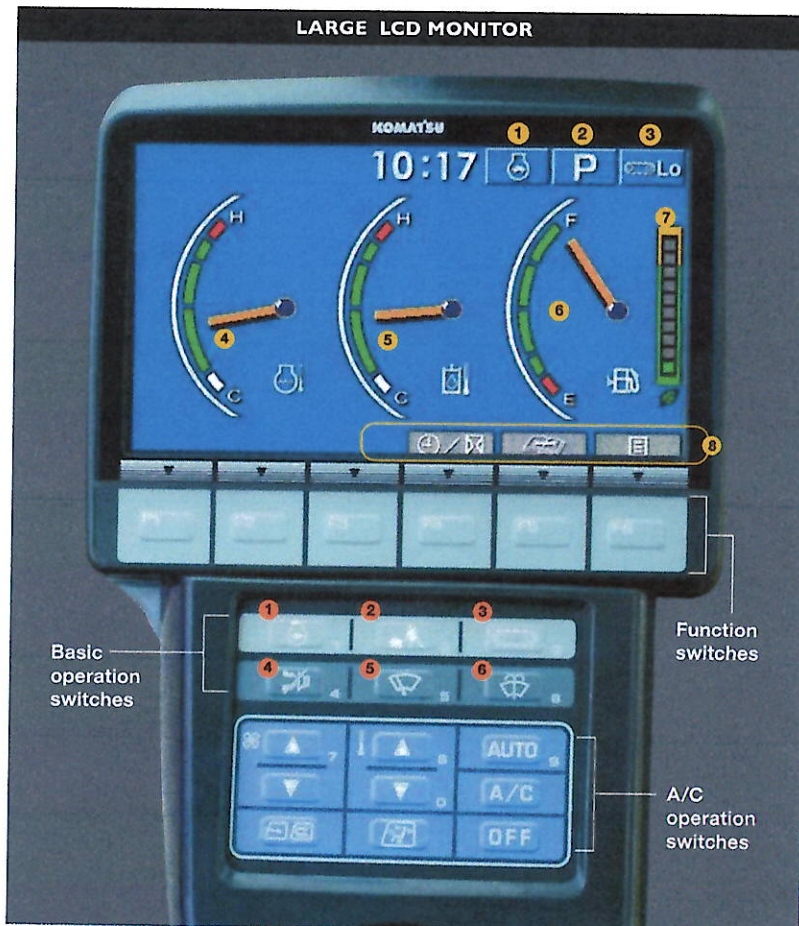

Large Multi-lingual LCD Monitor

A large user-friendly color monitor enables safe, accurate and smooth work. Improved screen visibility is achieved by the use of LCD that can easily be read at various angles and lighting conditions. Simple and easy to operate function switches. Function keys facilitate multi-function operations.

Displays data in 12 languages to globally support operators around the world.

Indicators

- | | |
|----------------------------------|-----------------------------------|
| 1 Auto-decelerator | 5 Hydraulic oil temperature gauge |
| 2 Working mode | 6 Fuel gauge |
| 3 Travel speed | 7 ECO gauge |
| 4 Engine water temperature gauge | 8 Function switches menu |

Basic operation switches

- | | |
|-------------------------|---------------------|
| 1 Auto-decelerator | 4 Buzzer cancel |
| 2 Working mode selector | 5 Wiper |
| 3 Traveling selector | 6 Windshield washer |

Equipment Management Monitoring System

Monitor function

Controller monitors engine oil level, coolant temperature, battery charge and air clogging, etc. If controller finds any abnormality, it is displayed on the LCD.

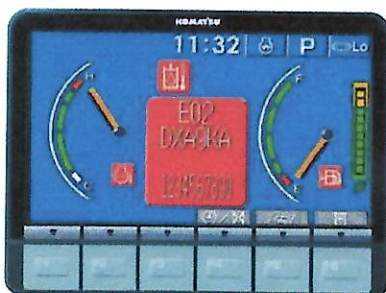

Maintenance function

Monitor informs replacement time of oil and filters on the LCD when the replacement interval is reached.



Trouble data memory function

Monitor stores abnormalities for effective troubleshooting.

KOMTRAX

Assists Customer's Equipment Management and Contributes to Fuel Cost Cutting

Equipment Management Support

KOMTRAX terminal installed on your machine collects and sends information such as machine location, working record, machine conditions, etc. using wireless communication. You can review the KOMTRAX data remotely via the online application. KOMTRAX not only gives you the informations on your machine, but also the convenience of managing your fleet on the Web.

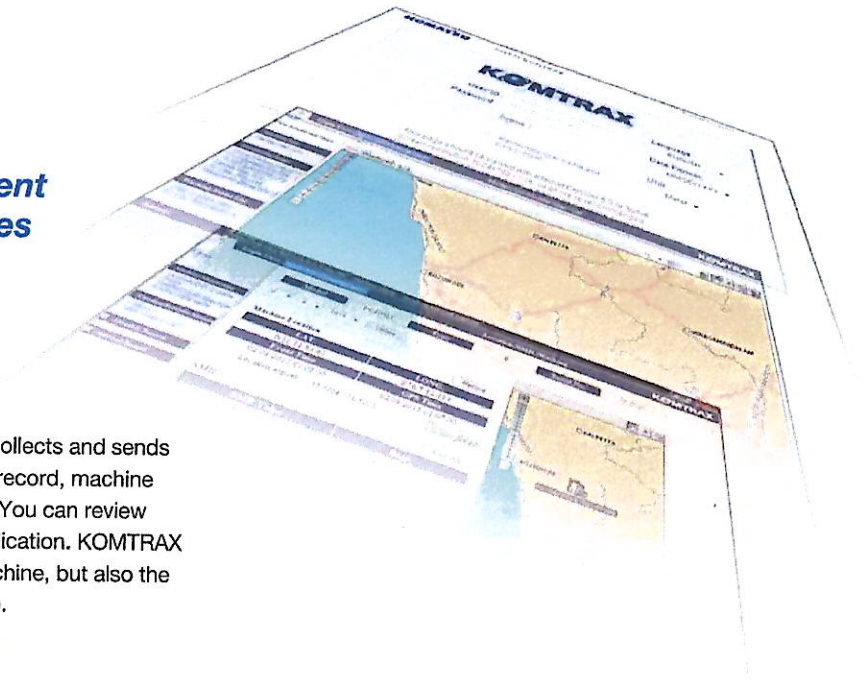

Location

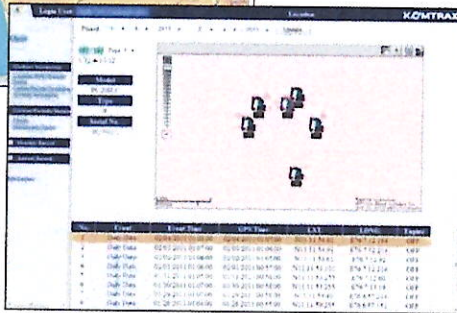

Movement generated position

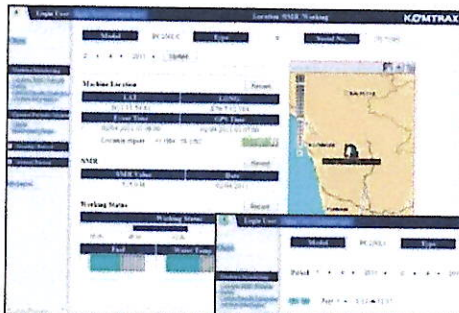

Operation map



Monthly status summary

Energy-saving Operation Support Report

KOMTRAX can provide various useful information which includes the energy-saving operation support report created based on the operating information of your machine such as fuel consumption and idle time.

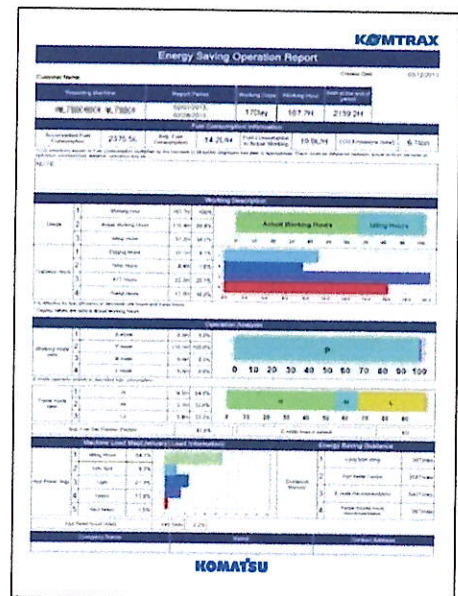

Image



MAINTENANCE

Easy Access to Engine Oil Filter and Fuel Drain Valve

Engine oil dipstick and fill, and fuel filter are mounted on same side to improve accessibility. Fuel drain valve are remotely mounted to improve accessibility.



Fuel drain valve

Easy Radiator Cleaning

Since radiator and oil cooler are arranged side-by-side, it is easy to clean, remove and install them.

Large-size Steps

On both right and left track frames are fixed with wider steps for easier maintenance.



Large Capacity Air Cleaner

Large capacity air cleaner is comparable to that of larger machines. The larger air cleaner can extend air cleaner life during long-term operation and prevents early clogging and resulting power decrease. Reliability is improved by a new seal design.



Long-life Oil, Filter

Uses high-performance filtering materials and long-life oil. Extends the oil and filter replacement interval.



Hydraulic oil filter

Engine oil & Engine oil filter	every 500 hours
Hydraulic oil	every 5000 hours
Hydraulic oil filter	every 1000 hours

Long Work Equipment Greasing Interval (Optional)

High quality bushings and resin shims are optionally available for work equipment pins excluding bucket, extending greasing interval to 500 hours.

Large Fuel Tank Capacity

Large fuel tank capacity extends operating hours before refueling. Fuel tank is treated for rust prevention and improved corrosion resistance.



RELIABILITY

High Pressure In-line Filter

In-line filters are provided at outlet port (Pressure side) of each pump to protect hydraulic system contamination.



In-line filters

Fuel Main-filter

The reliability of fuel systems is improved, because fuel main-filter removes contamination and sludge contained in fuel.



Equipped with Fuel Pre-filter (With Water Separator)

Removes water and contaminants in the fuel to prevent fuel problems.



O-ring Face Seal

The hydraulic hose seal method has been changed from a conventional taper seal to an O-ring seal. This provides improved sealing performance.

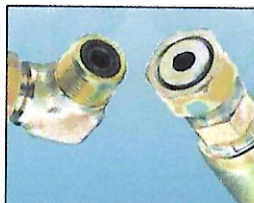

Metal Guard Rings

Metal guard rings protect all the hydraulic cylinders and improve reliability.

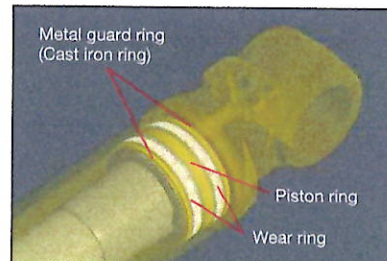

Shield Connectors

Shield connectors seal tight and have higher reliability.

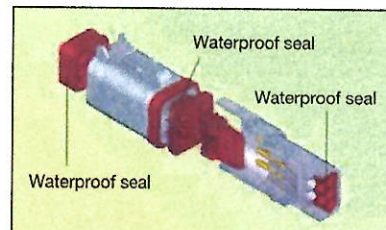

OPTIONS

- Cab front full height guard level 1 (ISO 10262)



- Cab front full height guard level 2 (ISO 10262)



- Additional front lights
- Rain visor



- Air pre-cleaner



- OPG top guard level 2 (ISO 10262)



- Strengthened track frame undercover



- Sun visor



- Seat, suspension



KOMATSU BRAND BUCKET

KOMATSU Brand Bucket for General Purpose with Wide Bucket Width

Me Bucket

- Low resistant excavation
- High productivity
- High durability
- High fuel efficiency

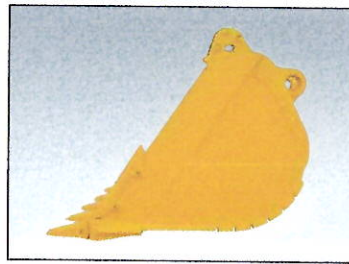

Conventional

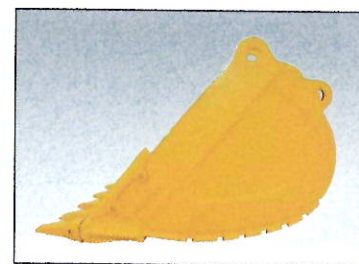

Me Bucket

Category and Feature

Category	Load / Wear / Soil (Application)	Image
Light Duty LD	Load Machine power remains low during the majority of the work. No impact load. Wear Material is not abrasive. Soil Dirt, loam and clay.	
General Purpose GP	Load Machine power is mostly medium, but occasionally high. Bucket movements are smooth with minor shock load. Bucket penetrates easily. Wear Material is lightly abrasive. Some sand may be medium abrasive. Soil Mostly loose sand, gravel and finely broken materials.	
Heavy Duty HD	Load Machine power is high during majority of the work. Medium, but continuous shock load. Wear Material is abrasive. Light scratch marks can be seen at the bucket. Soil Limestone, shot rock, compact mix of sand, gravel and clay.	
Extra Heavy Duty XHD	Load Machine power is high during most of the work, often at maximum. Dynamic shock loads are frequent and machine may shake. Wear Material is very abrasive. Large scratch marks are visible and, or deform metal. Works within heaps of rock with occasional un-shot rock and rock boulders. Soil Granite, basalt, quartz sand, compact and sticky clay.	

Bucket Line-up

Category	Bucket Type	Capacity (m ³)	Width* ¹ (mm)	Weight* ² (kg)	Tooth Quantity	Boom + Arm (m)		Tooth Type			
						7.06+3.38	6.67+2.40 SE Spec.	Vertical	Horizontal	PAB* ³	KMAX
LD	Conventional	2.20	<1715>	1395	5	●	—	✓	✓	✓	✓
		1.30	1270<1120>	1115	4	○	—	✓	✓	✓	✓
GP	Conventional	1.60	1420<1270>	1197	5	○	—	✓	✓	✓	✓
		1.90	1625<1475>	1358	5	○	—	✓	✓	✓	✓
		2.06	1715<1565>	1391	5	□	—	✓	✓	✓	✓
		1.90	1625<1475>	1965	5	○	—	✓	✓	✓	✓
HD	Me Bucket	1.90	1625<1475>	2025	5	○	—	✓	✓	✓	✓
		2.10	1625<1475>	1610	5	○	—	✓	✓	✓	✓
		2.80	1700<1525>	3080	5	×	□	✓	✓	✓	✓
XHD	Me Bucket	1.90	<1715>	2069	5	○	—	✓	✓	✓	✓
		2.10	1270<1120>	2165	5	□	—	✓	✓	✓	✓
		2.80	1700<1525>	3285	5	×	□	✓	✓	✓	✓

*1 With side cutters or side shrouds, < > without side cutters or side shrouds *2 With side cutters *3 PAB: Pin And Bushing system ☆: Heavy duty work, density up to 2.1 t/m³
 ○: General purpose use, density up to 1.8 t/m³ □: General purpose use, density up to 1.5 t/m³ ●: Light duty work, density up to 1.2 t/m³ ×: Not usable ✓: Selectable

Feature of [Me Bucket] (More suitable shape and Effectiveness Bucket)

High Productivity by Low-resistant Excavation

The new Ideal bucket profile produces lower resistance at inside & outside bucket and production will be greatly increased.

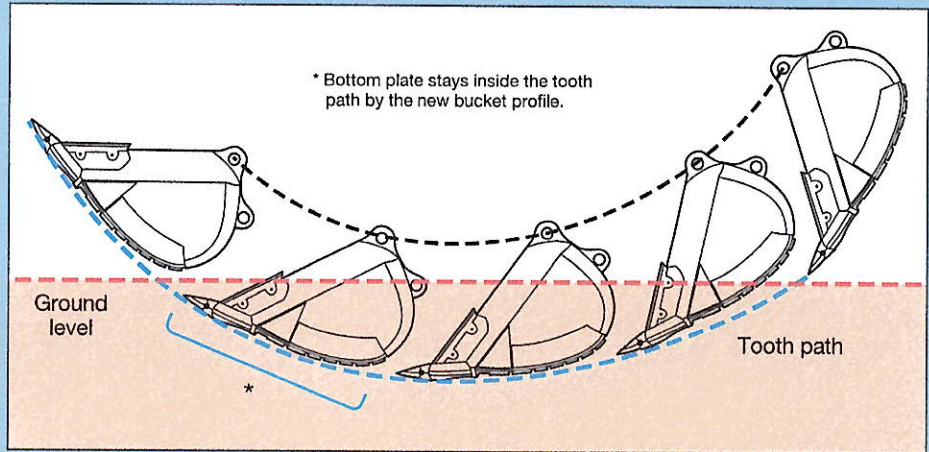

Feature of [PAB Tooth] (Pin And Bushing system Tooth)

- Able to fit on the bucket with horizontal pin type adapter
 - Easy change-out only with a ratchet wrench
 - Longer tooth life by easy rotation and turnover
 - Durable and reusable PAB pin with flat surface
- Limited to where horizontal pin type tooth is mainly used.

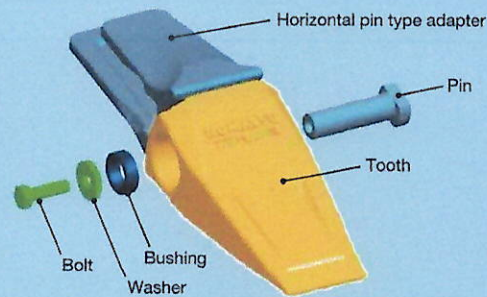

Set PAB tooth to horizontal pin type adapter



Insert exclusive pin to the adapter pin hole



Set bushing, washer and bolt and tighten by a ratchet wrench

PAB Tooth Line-up

Type	Style
Integrated Long Life IL	
Heavy Standard HS	
Heavy Rock HR	
Self Sharp SYL	
Hybrid HB	

Applicable Working Site

Application	Soil	Tight Material ← → Loose Material			
		Soiled Rock	Broken Rock	Clay	Gravel Sand
Extreme Heavy Excavation	HB				
Havy Excavation	HR				
	HS				
General Application	SYL				
	IL				
Loading/Unloading					

Special Purpose Bucket & Ripper

Feature and Specifications

Type	Feature	Bucket Capacity (SAE J 296 Heaped)	Width	Image
Ripper Bucket	Suitable for digging rock bed or hard clayey soil when normal buckets cannot penetrate deep enough. Loading is also possible.	1.10 m ³	1250 mm	
Single-shank Ripper	This ripper is used for site preparation prior to digging work, when it becomes necessary to remove rocks, pavement for other obstacles. Also effective for pulling out tree stumps.	—	—	



Photo may include optional equipment.

HENSLEY BRAND BUCKET

Diverse Bucket Capacity by Application Featuring "KMAX" Tooth System

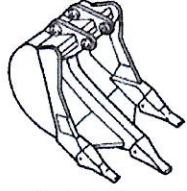
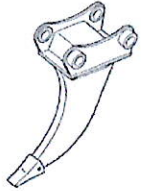

- Wide range selection for each application
- Larger profile and capacity to maximize production
- Multiple width options to meet specific job requirements and reduce backfill

Category and Recommended Applications

Category	Recommended Applications	Image
Trenching and Loading TL	Dirt, loam, sand, gravel, loose clay, abrasive soils with limited rock mixture.	
Heavy Duty Lip Bucket with Wear Plate HP	Abrasive soils, compact or dense clay, loose rock and gravel.	
Heavy Duty Lip Bucket with Wear Plate & Wear Strips HPS	Abrasive soils, compact or dense clay, loose rock and gravel.	
Extreme Duty Lip Bucket with Special Features HPX	Shot rock, stratified materials, quarry or tough, highly abrasive applications.	

Bucket Line-up

Category	Capacity (m³)	Width (mm)	Weight (kg)	Tooth Quantity	Boom + Arm (m)		Tooth Type
					7.06+3.38	6.67+2.40 SESpec.	
TL	1.12	762	1291	3	☆	☆	✓
	1.35	914	1444	4	☆	☆	✓
	1.64	1067	1565	4	☆	☆	✓
	1.94	1219	1724	5	○	☆	✓
	2.25	1372	1912	6	□	☆	✓
	2.55	1524	2012	6	●	○	✓
	2.87	1676	2171	7	■	□	✓
3.17	1829	2296	7	■	□	✓	
HP	1.12	762	1488	3	☆	☆	✓
	1.35	914	1677	4	☆	☆	✓
	1.64	1067	1818	4	☆	☆	✓
	1.94	1219	1994	5	○	☆	✓
	2.25	1372	2170	6	□	☆	✓
	2.55	1524	2540	6	●	○	✓
	2.87	1676	2764	7	■	□	✓
3.17	1829	2898	7	×	●	✓	
HPS	1.12	762	1583	3	☆	☆	✓
	1.35	914	1790	4	☆	☆	✓
	1.64	1067	1952	4	☆	☆	✓
	1.94	1219	2143	5	□	☆	✓
	2.25	1372	2342	6	●	☆	✓
	2.55	1524	2729	6	■	□	✓
	2.87	1676	2973	7	■	●	✓
3.17	1829	3126	7	×	●	✓	
HPX	1.12	762	1774	3	☆	☆	✓
	1.35	914	2019	4	☆	☆	✓
	1.64	1067	2192	4	○	☆	✓
	1.94	1219	2412	5	□	☆	✓
	2.25	1372	2643	6	●	○	✓
	2.55	1524	2903	6	■	□	✓
	2.87	1676	2989	7	×	●	✓
3.17	1829	3334	7	×	●	✓	

☆: Heavy duty work, density up to 2.1 t/m³ ○: General purpose use, density up to 1.8 t/m³
 □: General purpose use, density up to 1.5 t/m³ ●: Light duty work, density up to 1.2 t/m³
 ■: Light duty work, density up to 0.9 t/m³ ×: Not usable ✓: Selectable

Feature of KMAX Tooth System

- Better penetration and cycle times
- Hardness throughout the tooth
- Unique high strength design
- Unique reusable fastener
- Less "throw away" waste
- Fast tooth changeover



Tooth

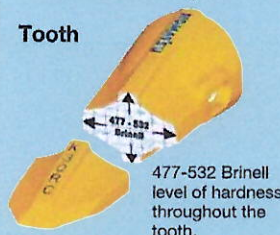

The KMAX RC style tooth shown here offers a consumption ratio of 60%.

Fastener

Simple, reusable fastener system saves time and money by unlocking with a simple 90-degree turn.

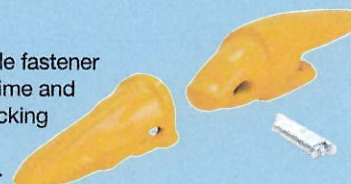

To lock, use the correct size socket, rotate the pin locking shaft 90-degree clockwise to finish the installation.

When removing the fastener, use the correct size socket to rotate the pin-locking shaft 90-degree counter-clockwise.

KMAX Tooth Line-up

Feature	Style
F Flare: Loose material for clean bottom and greater fill	
SYL Standard: General applications	
SD Chisel: General purpose tooth Designed for penetration	
RC Rock Chisel: Designed for penetration and long wear life	
T Tiger: Designed for good penetration with ribs for strength	
TV Tiger: Offers best penetration in tight material	
UT Twin Tiger: Offers longer life penetration for corners	
WT Twin Tiger: Designed for penetration for corners	

Some application may not have been available in your country or region. If you are interested in such application, please contact a KOMATSU office near you.

QUARRY HYDRAULIC EXCAVATOR

The PC450-8 is a specially designed for heavy-duty applications. The PC450-8 has strengthened work equipment and reinforced body parts for use in severe job sites such as quarry and gravel gathering, etc.

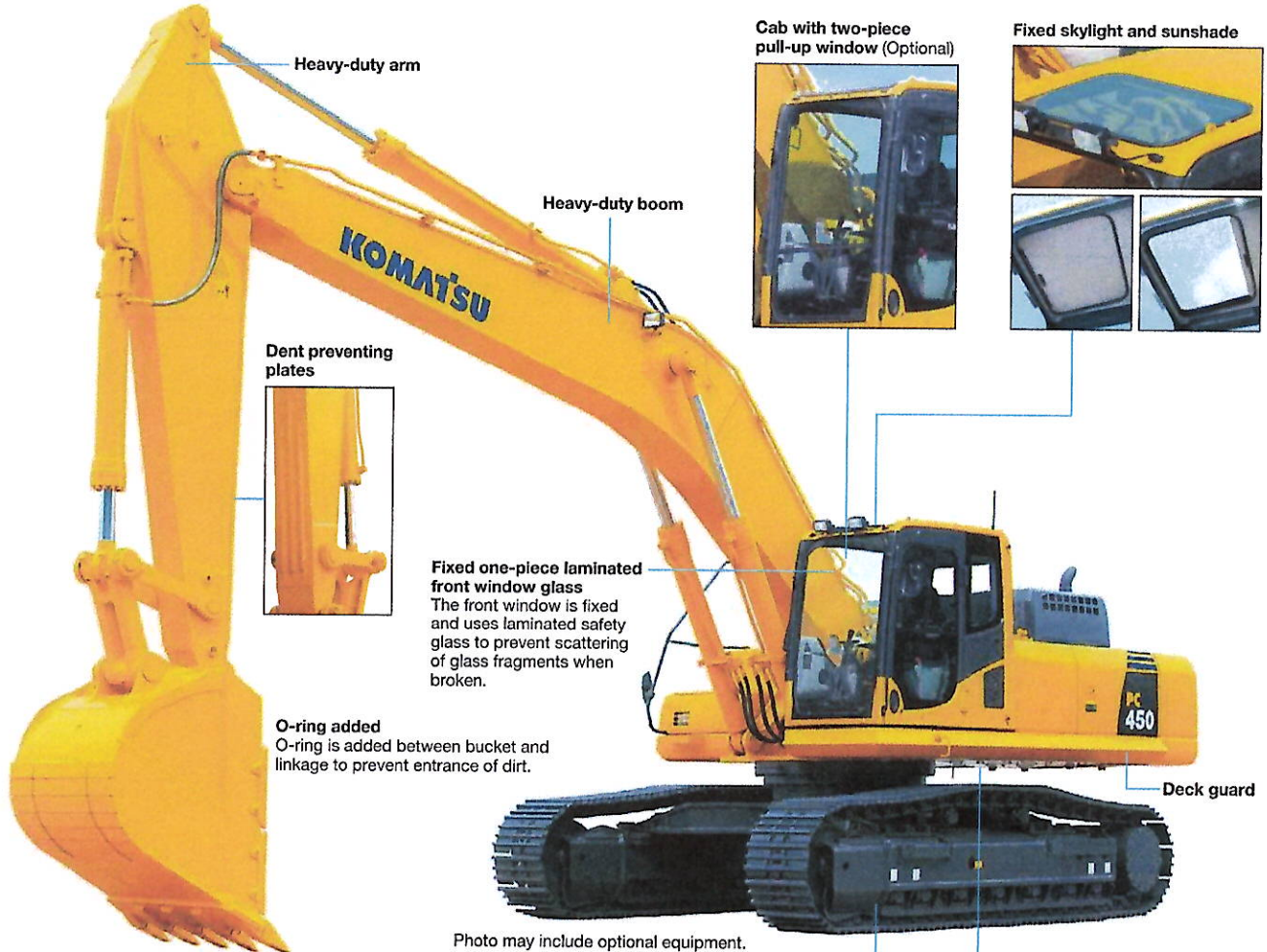
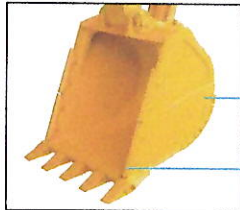

Photo may include optional equipment.

Quarry bucket

PC450-8 bucket is designed exclusively for quarry use and is higher strength for impact and wear. Various parts of work equipment are also strengthened.



Side reinforcement plates
16 mm thickness high-tensile strength steel used.

Side shrouds

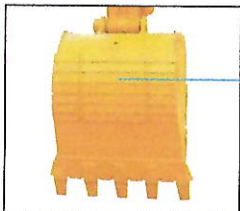

Bottom wear plate
19 mm thickness high-tensile strength steel used.

Full roller guard



Strengthened revolving frame underguard



Corner tooth adapters

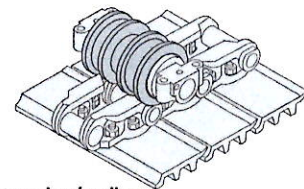
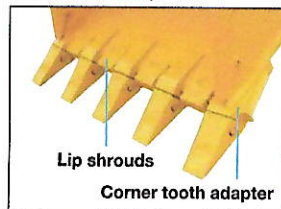

Double-flange track roller

Double-flange rollers guide track link correctly and extends life of undercarriage.

Number of double-flange track rollers

PC450-83 each side
PC450LC-84 each side

SE SPEC.

PC450LC-8 SE spec. is equipped with a large reinforced Me bucket for quarrying work. It increases the efficiency of loading a dump truck with large amounts of loose materials such as blasted rock.

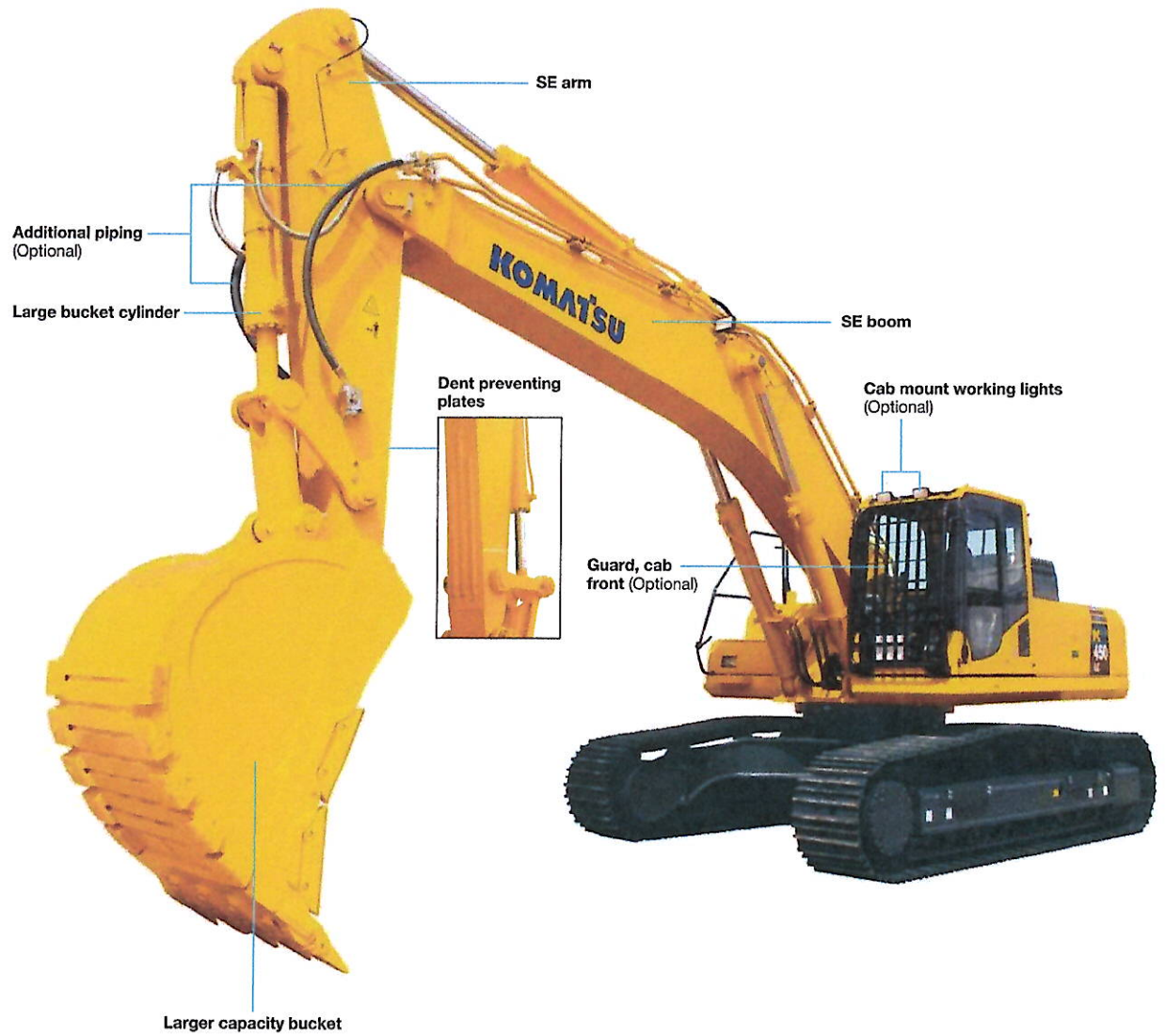

ATTACHMENT

Komatsu Genuine Attachment Tool

Komatsu-recommended attachment tools for hydraulic excavators
A wide range of attachment tools are provided to suit customers' specific applications.

Hydraulic breaker

The hydraulic breaker is an attachment tool used for crushing rock beds and paved surfaces, demolishing concrete structures, etc. The large gas chamber, ideal gas pressure ratio, and long-stroke piston deliver a powerful impact force. Since the breaker unit does not require an accumulator, the number of parts has been reduced, resulting in lower maintenance costs.



Crusher

This attachment tool is used for demolishing concrete structures. Since it does not have a striking mechanism and features low noise and low vibration, it is suitable for work in urban areas. The open-close cylinder is equipped with a speed-up valve for increasing work speed.



Primary crusher

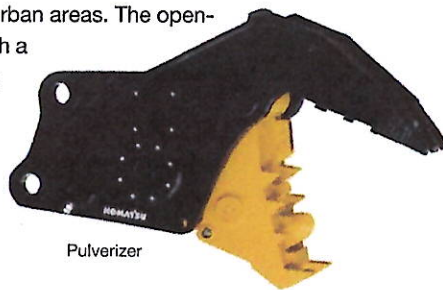

Pulverizer



Scrap & demolition shear

The scrap & demolition shears have multiple applications for both overhead-demolishing the steel structure (General structural steels) and cutting structural steel with required length at ground level. (In foundries, dumps, scrap yards)



Applications of Attachment Tools

Application/ Attachment Tool	Civil Engineering	Quarry	Demolition	Industrial Waste Disposal	Iron-making	Utility Construction	Rental
Hydraulic Breaker	○	○	○	○	○	○	○
Crusher (Primary Crusher)			○				○
Crusher (Pulverizer)			○	○			○
Scrap & Demolition Shear			○	○			○

KOMATSU TOTAL SUPPORT



Komatsu Total Support

To keep your machine available and minimize operation cost when you need it, Komatsu Distributor is ready to provide variety of support before and after procuring the machine.

Fleet recommendation

Komatsu Distributor can study customer job site and provide the most optimum fleet recommendation with detailed information to meet all of your application needs when you are considering to buy new machines or to replace the existing ones from Komatsu.

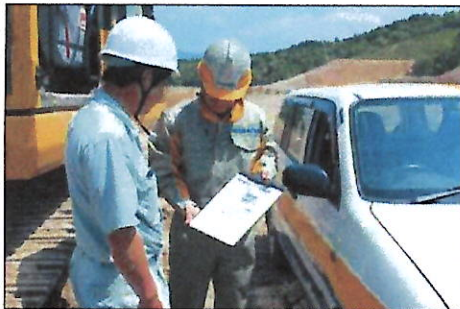

Product support

Komatsu Distributor secure the certain quality of machine will be delivered.

Parts availability

Komatsu Distributor is available for emergency inquiry by the customers for genuine, quality guaranteed Komatsu parts.

Technical support

Komatsu product support service (Technical support) are designed to help customer. Komatsu Distributor offers a variety of effective services how much Komatsu is dedicated to the maintenance and support of Komatsu machine.

- Preventive Maintenance (PM) clinic
- Oil & Wear analysis program
- Undercarriage inspection service, etc.

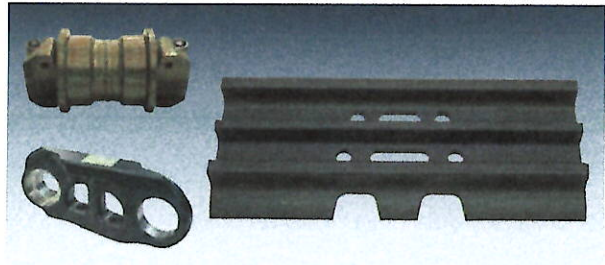

Repair & maintenance service

Komatsu Distributor offers quality repair service, periodic maintenance, and maintenance service to the customer, utilizing and promoting Komatsu developed programs.

Komatsu Reman (Remanufactured) components

Komatsu Reman products are the result of the implementation of the Komatsu global Reman policy which establishes and agrees to reduce the owning, operating and total Life Cycle Costs (LCC) to Komatsu's customer through prompt delivery, high quality and competitively priced in own remanufactured products (QDC).



SPECIFICATIONS



ENGINE

Model Komatsu SAA6D125E-5
 Type Water-cooled, 4-cycle, direct injection
 Aspiration Turbocharged, aftercooled
 Number of cylinders 6
 Bore 125 mm
 Stroke 150 mm
 Piston displacement 11.04 L
 Horsepower:
 SAE J1995 Gross 270 kW 362 HP
 ISO 9249 / SAE J1349 Net 257 kW 345 HP
 Rated rpm 1900 min⁻¹
 Fan drive method for radiator cooling Mechanical
 Governor All-speed control, electronic

U.S. EPA Tier 3 and EU Stage 3A emissions certified.



HYDRAULICS

Type. . HydraMind (Hydraulic Mechanical Intelligence New Design) system, closed-center system with load sensing valves and pressure compensated valves
 Number of selectable working modes 4
 Main pump:
 Type Variable displacement piston type
 Pumps for Boom, arm, bucket, swing, and travel circuits
 Maximum flow 690 L/min
 Supply for control circuit Self-reducing valve
 Hydraulic motors:
 Travel 2 x axial piston motor with parking brake
 Swing 1 x axial piston motor with swing holding brake
 Relief valve setting:
 Implement circuits 37.3 MPa 380 kg/cm²
 Travel circuit 37.3 MPa 380 kg/cm²
 Swing circuit 27.9 MPa 285 kg/cm²
 Pilot circuit 3.2 MPa 33 kg/cm²
 Hydraulic cylinders:
 (Number of cylinders – bore x stroke x rod diameter)
 Boom 2–160 mm x 1570 mm x 110 mm
 Arm
 Std 1–185 mm x 1985 mm x 130 mm
 SE 1–185 mm x 1820 mm x 120 mm
 Bucket
 Std 1–160 mm x 1270 mm x 110 mm
 SE 1–185 mm x 1160 mm x 120 mm



DRIVES AND BRAKES

Steering control Two levers with pedals
 Drive method Hydrostatic
 Maximum drawbar pull 330 kN 33700 kg
 Gradeability 70%, 35°
 Maximum travel speed: High 5.5 km/h
 (Auto-shift) Mid 4.0 km/h
 (Auto-shift) Low 3.0 km/h
 Service brake Hydraulic lock
 Parking brake Mechanical disc brake



SWING SYSTEM

Drive method Hydrostatic
 Swing reduction Planetary gear
 Swing circle lubrication Grease-bathed
 Service brake Hydraulic lock
 Holding brake/swing lock Mechanical disc brake
 Swing speed 9.1 min⁻¹



UNDERCARRIAGE

Center frame X-frame
 Track frame Box-section
 Seal of track Sealed track
 Track adjuster Hydraulic
 Number of shoes (Each side):
 PC450-8 46
 PC450LC-8 49
 Number of carrier rollers (Each side) 2
 Number of track rollers (Each side):
 PC450-8 7
 PC450LC-8 8



COOLANT AND LUBRICANT CAPACITY (REFILLING)

Fuel tank 650 L
 Coolant 36.0 L
 Engine 37.0 L
 Final drive (Each side) 10.5 L
 Swing drive 20.0 L
 Hydraulic tank 248 L



OPERATING WEIGHT (APPROXIMATE)

Operating weight including 7060 mm one-piece boom, 3380 mm arm, ISO 7451 heaped 1.90 m³ backhoe bucket, rated capacity of lubricants, coolant, full fuel tank, operator, and standard equipment.

Shoes	PC450-8		PC450LC-8	
	Operating Weight	Ground Pressure	Operating Weight	Ground Pressure
600 mm	43320 kg	80.7 kPa 0.82 kg/cm ²	44320 kg	76.8 kPa 0.78 kg/cm ²
700 mm	43740 kg	69.9 kPa 0.71 kg/cm ²	44770 kg	66.5 kPa 0.68 kg/cm ²

Operating weight including 6670 mm one-piece boom, 2400 mm arm, ISO 7451 heaped 1.90 m³ backhoe bucket, rated capacity of lubricants, coolant, full fuel tank, operator, and standard equipment.

Shoe	PC450-8 SE Spec.		PC450LC-8 SE Spec.	
	Operating Weight	Ground Pressure	Operating Weight	Ground Pressure
600 mm	43600 kg	81.2 kPa 0.83 kg/cm ²	44600 kg	77.3 kPa 0.79 kg/cm ²



DIMENSIONS

Model	PC450-8 / PC450LC-8	PC450-8 SE Spec. / PC450LC-8 SE Spec.
Boom Length	7060 mm	6670 mm
Arm Length	3380 mm	2400 mm
A Overall length	12040 mm	11635 mm
B Length on ground	6560 mm / 6725 mm	7860 mm
C Overall height (To top of boom)*	3660 mm	3665 mm
D Overall width	3430 mm	
E Overall height (To top of cab)*	3285 mm	
F Ground clearance, counterweight	1320 mm	
G Ground clearance (Minimum)	550 mm	
H Tail swing radius	3645 mm	
I Track length on ground	4020 mm / 4350 mm	4020 mm / 4350 mm
J Track length	5055 mm / 5385 mm	5055 mm / 5385 mm
K Track gauge	2740 mm	
L Width of crawler	3340 mm	
M Shoe width	600 mm	
N Grouser height	37 mm	
O Machine cab height	2920 mm	
P Machine cab width	3165 mm	
Q Distance, swing center to rear end	3605 mm	

* Including grouser height

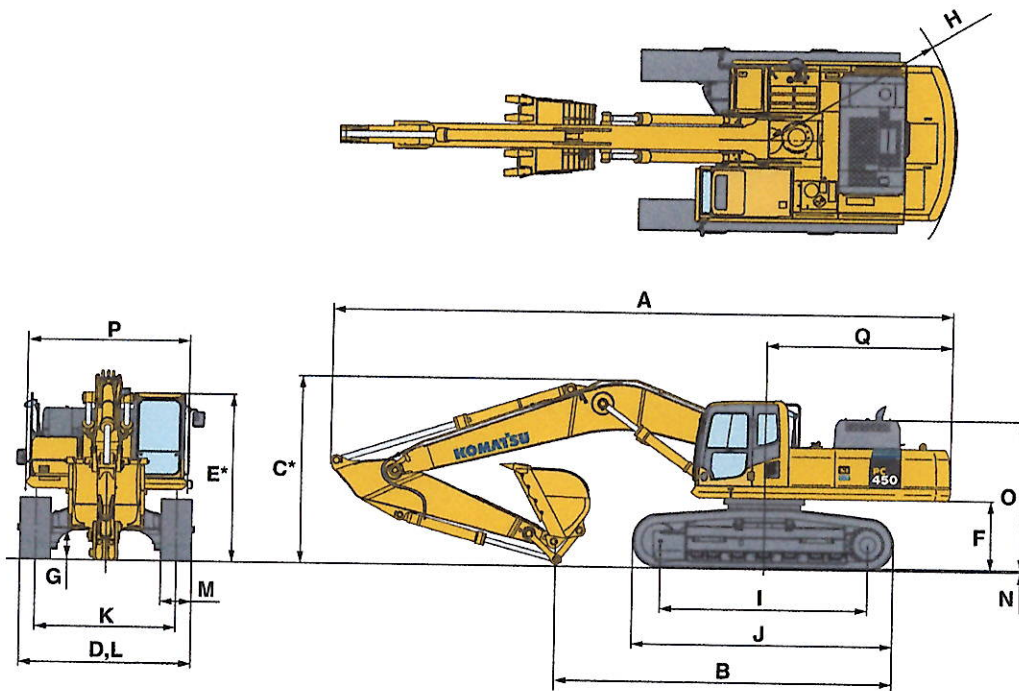



WORKING RANGE

Model	PC450-8 / PC450LC-8	PC450-8 SE Spec. / PC450LC-8 SE Spec.
Boom Length	7060 mm	6670 mm
Arm Length	3380 mm	2400 mm
A Max. digging height	10925 mm	10155 mm
B Max. dumping height	7625 mm	6605 mm
C Max. digging depth	7790 mm	6740 mm
D Max. vertical wall digging depth	6600 mm	3810 mm
E Max. digging depth of cut for 2440 mm level	7650 mm	6570 mm
F Max. digging reach	12005 mm	10975 mm
G Max. digging reach at ground level	11800 mm	10750 mm
H Min. swing radius	4805 mm	4470 mm
SAE 1179 Rating	Bucket digging force at power max.	243 kN 24800 kg
	Arm crowd force at power max.	225 kN 22900 kg
ISO 6015 Rating	Bucket digging force at power max.	278 kN 28300 kg
	Arm crowd force at power max.	233 kN 23800 kg

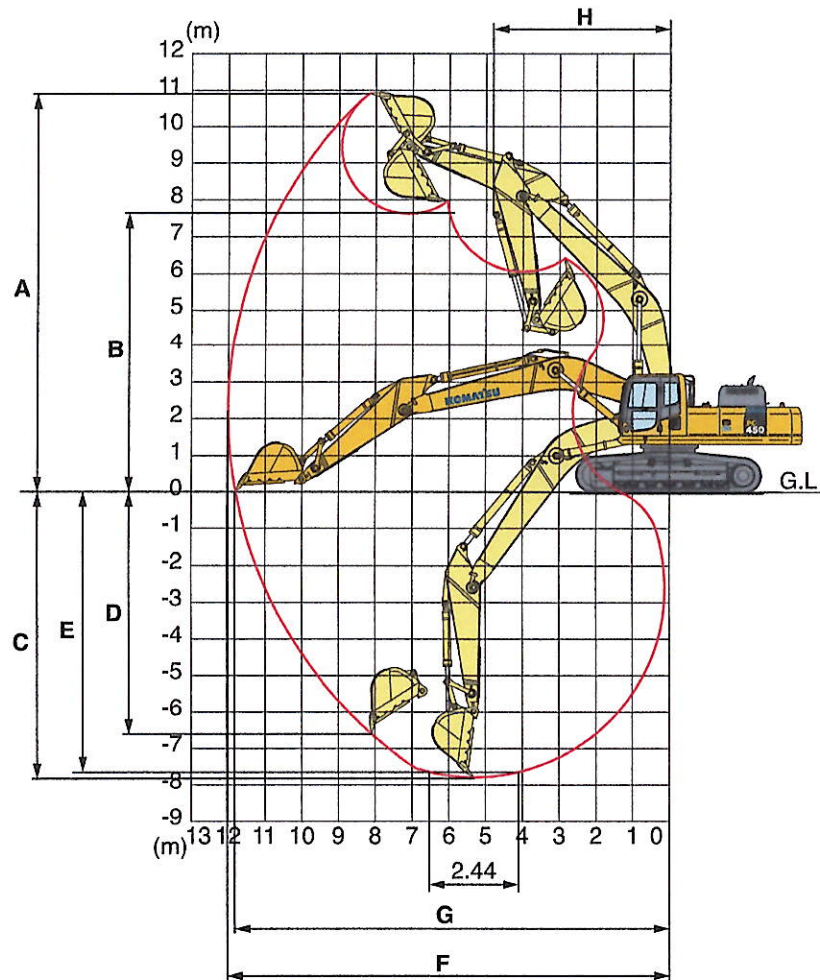



LIFTING CAPACITY WITH LIFTING MODE

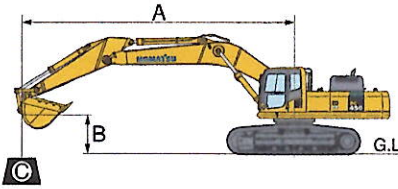

PC450-8 / PC450LC-8 / PC450-8 SE Spec. / PC450LC-8 SE Spec.

- A: Reach from swing center
- B: Bucket hook height
- C: Lifting capacity
- Cf: Rating over front
- Cs: Rating over side
- ⊗: Rating at maximum reach

PC450-8		Boom: 7060 mm		Arm: 3380 mm		Bucket: 1.90 m ³ ISO 7451 heaped		Shoe: 600 mm triple grouser					
B	A	⊗ MAX		9.0 m		7.5 m		6.0 m		4.5 m		3.0 m	
		Cf	Cs	Cf	Cs	Cf	Cs	Cf	Cs	Cf	Cs	Cf	Cs
7.5 m		*6000 kg	5850 kg										
6.0 m		*6000 kg	4850 kg	8750 kg	5700 kg	*9600 kg	8200 kg						
4.5 m		*6200 kg	4250 kg	8550 kg	5500 kg	*10600 kg	7800 kg	*12800 kg	11500 kg				
3.0 m		6350 kg	3950 kg	8300 kg	5300 kg	11400 kg	7350 kg	*14950 kg	10650 kg	*20900 kg	16850 kg		
1.5 m		6200 kg	3800 kg	8000 kg	5050 kg	10900 kg	6900 kg	15850 kg	9950 kg	*17650 kg	15450 kg		
0 m		6350 kg	3850 kg	7800 kg	4850 kg	10550 kg	6600 kg	15300 kg	9450 kg	*17800 kg	14950 kg		
-1.5 m		6800 kg	4150 kg	7700 kg	4750 kg	10400 kg	6450 kg	15050 kg	9250 kg	*22950 kg	14950 kg		
-3.0 m		7750 kg	4800 kg	7750 kg	4750 kg	10400 kg	6450 kg	15100 kg	9300 kg	*20950 kg	15100 kg	*21700 kg	*21700 kg
-4.5 m		*9100 kg	6050 kg			*10350 kg	6600 kg	*13750 kg	9500 kg	*17700 kg	15450 kg	*22350 kg	*22350 kg
-6.0 m		*8050 kg	*8050 kg					*9450 kg	*9450 kg	*12600 kg	*12600 kg		

PC450LC-8		Boom: 7060 mm		Arm: 3380 mm		Bucket: 1.90 m ³ ISO 7451 heaped		Shoe: 600 mm triple grouser					
B	A	⊗ MAX		9.0 m		7.5 m		6.0 m		4.5 m		3.0 m	
		Cf	Cs	Cf	Cs	Cf	Cs	Cf	Cs	Cf	Cs	Cf	Cs
7.5 m		*6000 kg	5950 kg										
6.0 m		*6000 kg	4950 kg	*8850 kg	5800 kg	*9600 kg	8350 kg						
4.5 m		*6200 kg	4350 kg	*9250 kg	5650 kg	*10600 kg	7950 kg	*12800 kg	11700 kg				
3.0 m		*6550 kg	4000 kg	9400 kg	5400 kg	*11750 kg	7500 kg	*14950 kg	10850 kg	*20900 kg	17150 kg		
1.5 m		7150 kg	3900 kg	9150 kg	5150 kg	12450 kg	7050 kg	*16650 kg	10100 kg	*17650 kg	15750 kg		
0 m		7300 kg	3950 kg	8950 kg	4950 kg	12100 kg	6750 kg	*17300 kg	9650 kg	*17800 kg	15200 kg		
-1.5 m		7800 kg	4250 kg	8850 kg	4850 kg	11900 kg	6600 kg	*17100 kg	9450 kg	*22950 kg	15200 kg		
-3.0 m		8900 kg	4900 kg	8850 kg	4900 kg	11900 kg	6550 kg	*16000 kg	9450 kg	*20950 kg	15400 kg	*21700 kg	*21700 kg
-4.5 m		*9100 kg	6200 kg			*10350 kg	6750 kg	*13750 kg	9650 kg	*17700 kg	15750 kg	*22350 kg	*22350 kg
-6.0 m		*8050 kg	*8050 kg					*9450 kg	*9450 kg	*12600 kg	*12600 kg		

PC450-8 SE Spec.		Boom: 6670 mm		Arm: 2400 mm		Me bucket: 2.80 m ³ ISO 7451 heaped		Shoe: 600 mm triple grouser					
B	A	⊗ MAX		9.0 m		7.5 m		6.0 m		4.5 m		3.0 m	
		Cf	Cs	Cf	Cs	Cf	Cs	Cf	Cs	Cf	Cs	Cf	Cs
7.5 m		*10850 kg	8300 kg										
6.0 m		10050 kg	6500 kg			*11050 kg	7900 kg	*12700 kg	11900 kg				
4.5 m		8750 kg	5550 kg			11700 kg	7550 kg	*14400 kg	11150 kg	*19050 kg	18100 kg		
3.0 m		8100 kg	5050 kg	8200 kg	5100 kg	11200 kg	7100 kg	*16150 kg	10350 kg				
1.5 m		7900 kg	4900 kg	8000 kg	4950 kg	10900 kg	6800 kg	15700 kg	9700 kg				
0 m		8200 kg	5050 kg	7900 kg	4850 kg	10650 kg	6550 kg	15300 kg	9350 kg	*22450 kg	14350 kg		
-1.5 m		9000 kg	5550 kg			10550 kg	6500 kg	15250 kg	9300 kg	*20500 kg	15000 kg	*20000 kg	*20000 kg
-6.0 m													

PC450LC-8 SE Spec.		Boom: 6670 mm		Arm: 2400 mm		Me bucket: 2.80 m ³ ISO 7451 heaped		Shoe: 600 mm triple grouser					
B	A	⊗ MAX		9.0 m		7.5 m		6.0 m		4.5 m		3.0 m	
		Cf	Cs	Cf	Cs	Cf	Cs	Cf	Cs	Cf	Cs	Cf	Cs
7.5 m		*10500 kg	8100 kg										
6.0 m		*10100 kg	6250 kg			*10500 kg	7650 kg	*12200 kg	11750 kg				
4.5 m		9650 kg	5300 kg	9200 kg	5000 kg	*11200 kg	7300 kg	*13950 kg	11050 kg	*18650 kg	18200 kg		
3.0 m		8950 kg	4800 kg	9000 kg	4800 kg	*12050 kg	6850 kg	*15650 kg	10250 kg				
1.5 m		8750 kg	4650 kg	8800 kg	4600 kg	12150 kg	6600 kg	*16500 kg	9600 kg				
0 m		9050 kg	4800 kg	8700 kg	4500 kg	11900 kg	6350 kg	*16550 kg	9250 kg	*21750 kg	14100 kg		
-1.5 m		*10000 kg	5300 kg			*11850 kg	6300 kg	*15600 kg	9150 kg	*20050 kg	15100 kg	*19650 kg	*19650 kg
-6.0 m													

* Load is limited by hydraulic capacity rather than tipping. Ratings are based on SAE J1097. Rated loads do not exceed 87% of hydraulic lift capacity or 75% of tipping load.



STANDARD EQUIPMENT

ENGINE:

- Automatic engine warm-up system
- Corrosion resistor
- Dry type air cleaner, double element
- Engine, Komatsu SAA6D125E-5
- Engine overheat prevention system
- Fuel pre-filter (With water separator)
- Radiator and oil cooler dust proof net
- Water separator

ELECTRICAL SYSTEM:

- Alternator, 24 V/50 A
- Auto-decelerator
- Batteries, 2 X 12 V/110 Ah
- Working light, 2 (Boom and RH)

HYDRAULIC SYSTEM:

- Boom holding valve
- Long lubricating intervals for implement bushings
- Power maximizing system
- Pressure Proportional Control (PPC) hydraulic control system
- Two-mode setting for boom
- Working mode selection system

GUARDS AND COVERS:

- Fan guard structure
- Track roller guards (Full length)

UNDERCARRIAGE:

- Hydraulic track adjusters (Each side)
- Track roller
 - PC450-8, 7 each side
 - PC450LC-8, 8 each side

- Track shoe
 - PC450-8, 600 mm triple grouser
 - PC450LC-8, 600 mm triple grouser

OPERATOR ENVIRONMENT:

- Large multi-lingual LCD monitor
- Rear view mirrors (RH and LH)
- ROPS cab (ISO 12117-2)
- Seat belt, retractable

OTHER EQUIPMENT:

- Counterweight, 9220 kg
- Electric horn
- Rear reflector
- Slip-resistant plates
- Travel alarm



OPTIONAL EQUIPMENT

ELECTRICAL SYSTEM:

- Alternator, 24 V/60 A
- Batteries, 2 X 12 V/140 Ah
- Working lights (2 on cab)

HYDRAULIC SYSTEM:

- Attachment piping
- Long lubricating intervals for work equipment bushings
- Service valve

UNDERCARRIAGE:

- Shoes, triple grouser shoes
 - PC450-8, 700 mm
 - PC450LC-8, 700 mm
- Track frame undercover
- Variable track gauge

OPERATOR ENVIRONMENT:

- A/C with defroster
- Bolt-on top guard, OPG top guard level 2 (ISO 10262)
- Cab accessories
 - Rain visor
 - Sun visor
- Cab front guard
 - Full height guard, OPG level 1 (ISO 10262)
 - Full height guard, OPG level 2 (ISO 10262)
 - Half height guard
- Heater with defroster
- Rear view mirror (Rear and sidewise)
- Rear view monitor system
- Seat, suspension
- Seat, suspension with heater

WORK EQUIPMENT:

- Arms
 - 3380 mm arm assembly
 - 2400 mm SE arm assembly
- Booms (Backhoe)
 - 7060 mm boom assembly
 - 6670 mm SE boom assembly

OTHER EQUIPMENT:

- Electric grease gun
- Fuel refill pump
- Pre-cleaner

KOMATSU®