

KOMATSU®

PC138USLC-8

With Tier 3 Engine

NET HORSEPOWER

68 kW **92 HP** @ 2200 rpm

OPERATING WEIGHT

14110–14773 kg **31,107–32,568 lb**

BUCKET CAPACITY

0.26–0.76 m³ **0.34–1.00 yd³**

PC
138US
LC



Photo may include optional equipment.

HYDRAULIC EXCAVATOR

WALK-AROUND

Komatsu's PC138USLC-8 Series Hydraulic Excavators have a short tail swing profile, designed specifically for work in confined areas. By reducing tail swing, the PC138USLC-8 is perfect for work on roadways, bridges, in urban areas, or anywhere space is limited. The PC138USLC-8 Series provides the performance and productivity you expect from Komatsu equipment.

Ecology and Economy Features

● ***Low Emission Engine***

A powerful turbocharged and air-to-air aftercooled Komatsu SAA4D95LE-5 engine provides 68 kW **92 HP** (net). This engine is EPA Tier 3 emissions ready, without sacrificing power or machine productivity.

● ***Low Operational Noise***

The dynamic noise is reduced providing low noise operation.

Productivity Features

● ***High Mobility***

- Large drawbar pull and steering force are evident when operating on a slope or other rough terrain.
- The machine travel speed changes automatically to Hi or Lo at optimal points according to the travel load.

● ***High Stability***

The PC138USLC-8 offers exceptional lifting capacity and high stability with a large counterweight.

● ***Mode Selection***

Five working modes designed to match engine speed, pump delivery, and system pressure.

Upper Structure Features

- Slip resistant surfaces for improving foot traction
- Rear view camera



Excellent Reliability and Durability

- High rigidity work equipment
- Sturdy frame structure
- Reliable Komatsu manufactured major components



KOMTRAX equipped machines can send location, SMR and operation maps to a secure website utilizing wireless technology. Machines also relay error codes, cautions, maintenance items, fuel levels, and much more.

Operational Features

• **Small Tail Swing**

- Excellent operation in tight quarters is improved due to the small tail swing radius design
- Round profile provides short protrusion of front and rear portions of the upper structure.
- Occupies a small road width for operation in congested areas.
 - **Wider Working Ranges:** Job sites that require a long attachment reach, such as demolition and slope cutting, also benefit from the increased digging and dumping ranges of the PC138USLC-8.



Photo may include optional equipment.

Easy Maintenance

- Long replacement interval of hydraulic oil and hydraulic filter
- Remote mounted engine oil filter and fuel drain valve for easy access
- Equipped with the fuel pre-filter as standard (with water separator)
- Side-by-side cooling concept enables servicing of individual cooling modules.
- Equipped with the Equipment Management Monitoring System (EMMS).

Larger Comfortable Cab

- Low noise cab design with viscous cab mounting
- Sliding convex door facilitates easy entrance in confined areas.
- Large cab improves working space.

NET HORSEPOWER
68 kW 92 HP @ 2200 rpm

OPERATING WEIGHT
14110 – 14773 kg
31,107 – 32,568 lb

BUCKET CAPACITY
0.26 – 0.76 m³
0.34 – 1.00 yd³

Large TFT LCD Monitor

- Easy-to-see and use 7" large multi-function color monitor
- Can be displayed in 12 languages

TFT : Thin Film Transistor
LCD : Liquid Crystal Display

PRODUCTIVITY & ECOLOGY FEATURES

Komatsu Technology



Komatsu develops and produces all major components in house such as engines, electronics and hydraulic components. Combining “Komatsu Technology”, and customer feedback, Komatsu is achieving great advancements in technology. To achieve both high levels of productivity and economical performance, Komatsu has developed the main components with a total control system. The result is a new generation of high performance and environment-friendly excavators.

Low Emission Engine

Komatsu SAA4D95LE-5 is EPA Tier 3 emissions ready.

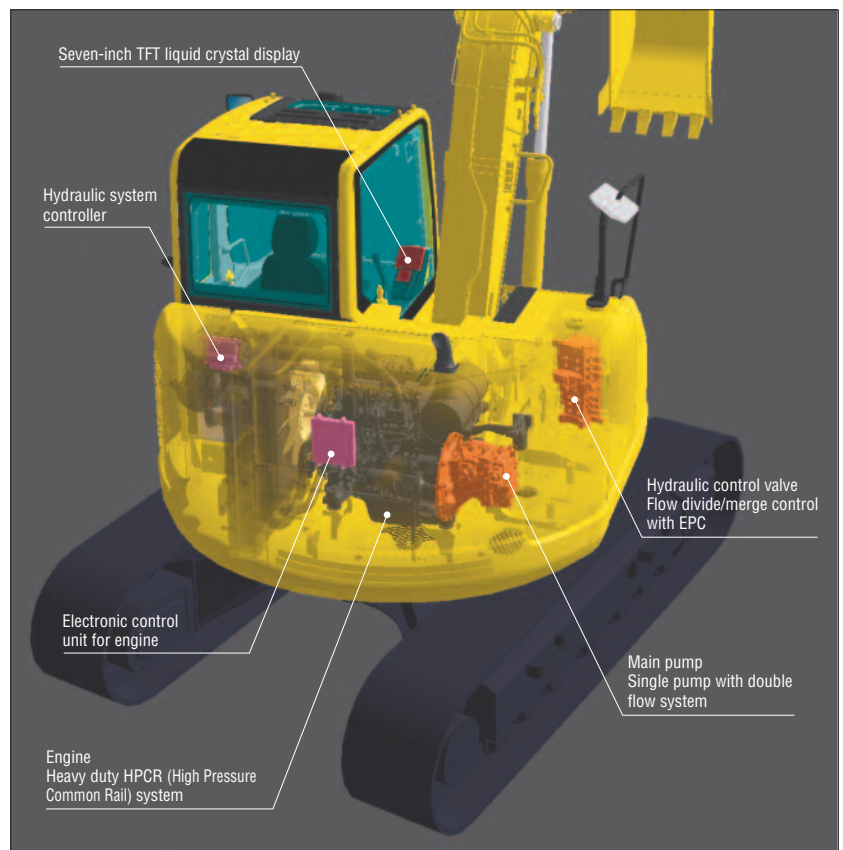
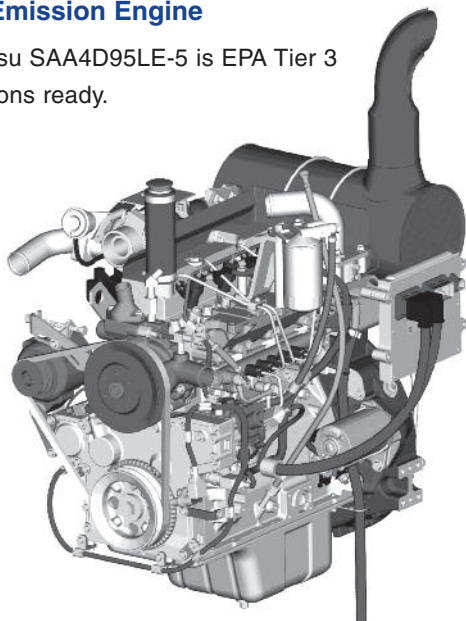

Low Operational Noise

Enables low noise operation by using the low-noise emitting engine and methods to reduce noise at the source.

Electronically controlled common rail type engine

- Multi-staged injection
- Highly rigid cylinder block

Low noise design

- Optimal arrangement of sound absorbing materials
- Partition between the cab and engine room
- Increased sound absorption around main control valve

Large Digging Forces

The PC138USLC-8 has a large bucket digging force and arm crowd force, that facilitate hard digging. Digging force ISO rating.

	PC138USLC-8
Bucket digging force	93.2 kN 9500 kgf 20,950 lbf
Arm crowd force	61.8 kN 6300 kgf 13,890 lbf

High Mobility

The PC138USLC-8's exceptional travel performance is provided by single pump with double flow, and it demonstrates superb maneuverability while operating at its optimum travel speed. It exhibits a large drawbar pull for moving around job sites, traveling in rough terrain, and climbing steep slopes.



High Stability

The PC138USLC-8 offers exceptional lifting capacity and high stability with a large counterweight that increases lifting capacity 10% compared to the previous model and increases over side lifting capacity 5% more than the PC120LC-6.



Working Modes Selectable

The PC138USLC-8 excavator is equipped with five working modes (P, E, L, B and ATT mode). Each mode is designed to match engine speed and pump speed with the current application. This provides the flexibility to match equipment performance to the job at hand.

Working Mode	Application	Advantage
P	Power mode	<ul style="list-style-type: none"> Maximum production/power Fast cycle times
E	Economy mode	<ul style="list-style-type: none"> Good cycle times Better fuel economy
L	Lifting mode	<ul style="list-style-type: none"> Engine RPM reduction
B	Breaker mode	<ul style="list-style-type: none"> Optimum engine rpm, hydraulic flow
ATT	Attachment mode	<ul style="list-style-type: none"> Optimum engine rpm, hydraulic flow, 2-way

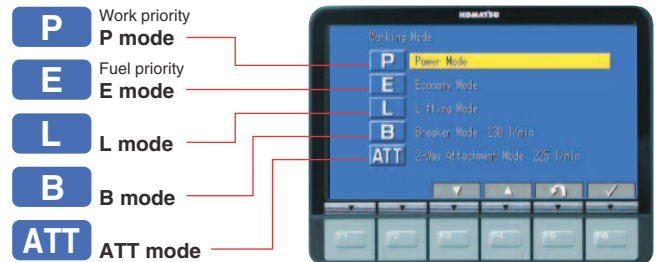

Eco-gauge that Assists Energy-saving Operations

Equipped with the Eco-gauge that can be recognized at a glance on the right of the multi-monitor for environment-friendly energy-saving operations. Allows the operator to maintain work in the green zone and reduce fuel consumption.



Idling Caution

To prevent unnecessary fuel consumption, an idling caution is displayed on the monitor, if the engine idles for 5 minutes or more.



OPERATIONAL FEATURES

Operation with a Small Tail Swing Even in Confined Areas

Short Implement Swing Radius:

Boom raising angle of the PC138USLC-8 is larger than a conventional profile excavator. The result is reduced front implement swing radius.

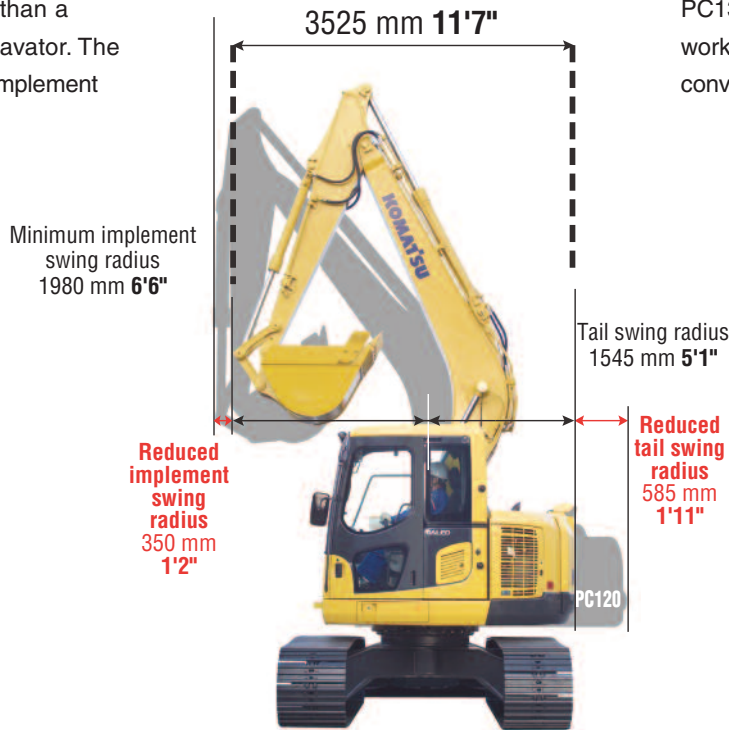

Short Tail Swing Radius:

Short tail swing radius of the PC138USLC-8 allows the machine to work in more confined areas than a conventional machine.

Roadwork

When performing roadwork, protrusion of the machine into the unoccupied lane is kept minimal since the rear portion of the upper structure protrudes slightly from the track at swing. This allows a dump truck to be positioned closer to the track of the machine. The operator is able to load materials efficiently onto the front of the dump body at ease since ample dumping reach is assured for the loading. Larger working spaces are not required for the machine.

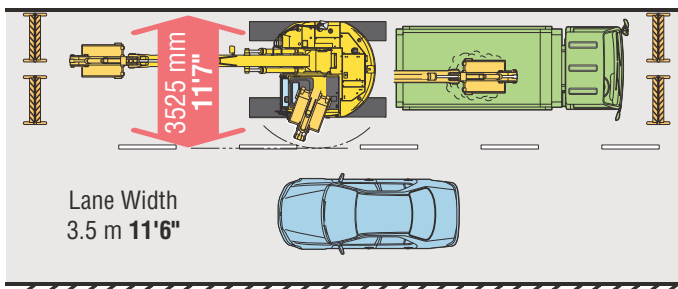

Logging and forest roadwork

Since the protrusion of the rear portion of the upper structure is kept minimal, there is less possibility of the counterweight hitting against a tree or a slope, allowing the operator to operate the machine at ease.

Furthermore, large digging height facilitates slope finishing work. Large drawbar pull assures smooth and powerful traveling even on rough terrain.

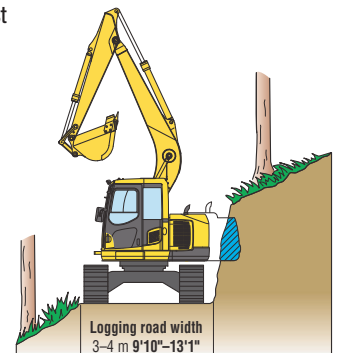

Demolition

The machine needs less working space and can perform efficient demolition work since it has large and ample digging height.

Wider Working Ranges

Raising the boom on the PC138USLC-8 to a wider angle enhances overall working performance. Job sites that require a long upper reach, such as demolition and slope cutting, also benefit from the increased digging and dumping ranges of the PC138USLC-8.

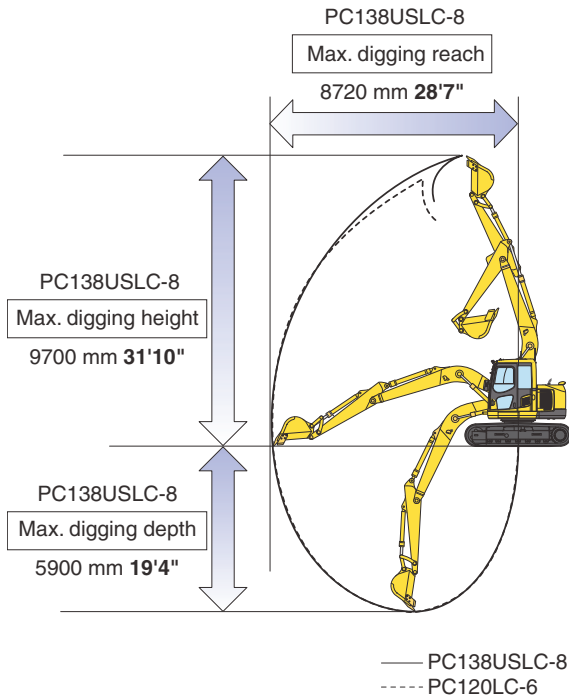

Round Profile of both Front and Rear Portion of the Upper Structure

Komatsu hydraulic excavators with small tail swing radius design adopt the round profile for both left and right corners of the front portion of the upper structure as well as its rear portion that features less protrusion from the track at swing. The round profile design allows the machine to work in tight quarters.

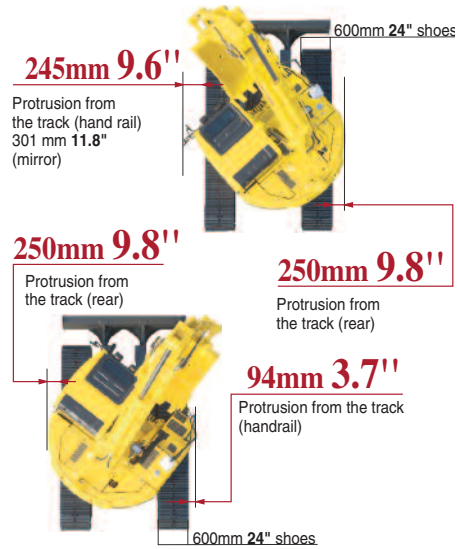

	PC138USLC-8	PC120LC-6
Maximum digging height	9700 mm 31'10"	8970 mm 29'5"
Maximum digging depth	5900 mm 19'4"	6015 mm 19'9"
Maximum dumping height	7350 mm 24'1"	6535 mm 21'5"



WORKING ENVIRONMENT

PC138USLC-8 cab interior is spacious and provides a comfortable working environment...

Large Comfortable Cab

Multi-position Controls

The multi-position, PPC (pressure proportional control) levers allow the operator to work in comfort while maintaining precise control. A double-slide mechanism allows the seat and controllers to move together or independently, allowing the operator to position the seat and controllers for maximum productivity and comfort.

Low Cab Noise

The newly-designed cab is highly rigid and has excellent sound absorption ability. Through improvement of noise source reduction and use of low noise engine, hydraulic equipment, and air conditioner allows this machine to generate a low level of noise similar to that of a modern automobile.

Comfortable Ride with Viscous Cab Mounts

Viscous mounts are adopted for the cab mount system. The cab mount system absorbs shocks and aids vibration reduction to provide comfortable ride.

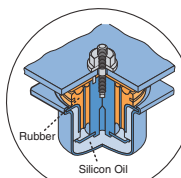

Pressurized Cab

Auto air conditioner, air filter, and a higher internal air pressure help prevent external dust from entering the cab.



Wide Newly-designed Cab

Large cab provides ample operation space and includes a high-back seat. The cab has a wide doorway for easy access.



Automatic Air Conditioner

Enables you to easily and precisely set cab temperature with the instruments on the large LCD.

The bi-level control function keeps the inside of the cab comfortable from top to bottom throughout the year. Defroster function keeps cab glass clear.



Sliding Convex Door

The sliding convex door facilitates easy entrance in confined areas.



Features

New Cab Design for Hydraulic Excavators

The cab is designed specifically for hydraulic excavators and gains reinforced strength from the pipe-structured cab framework. The cab framework provides the high durability and impact resistance with very high impact absorbency.



Skylight

Skylight can be opened for additional overhead visibility.



Travel Alarm

An alarm is installed as standard equipment to give other workers a warning when the machine travels in forward or reverse.

Slip Resistant Plates

Durable slip resistant plates maintain superior foot traction.



Lock Lever

When lock lever is placed in lock position all hydraulic controls (travel, swing, boom, arm and bucket) are inoperable.



Lever shown in lock position

Work Area Rear View Camera System

The operator can view to the rear of the machine through the color monitor screen on the multi-function panel.



Monitor for rear view camera

Wide Visibility

The right side window pillar has been removed and the rear pillar reshaped to provide improved visibility.



MAINTENANCE FEATURES

Easy Maintenance

Komatsu designed the PC138USLC-8 to have easy service access. By doing so, routine maintenance and servicing are less likely to be skipped, which can mean a reduction in costly downtime later on. Here are some of the many service features found on the PC138USLC-8.

Optimum Maintenance Layout

With the left and right side service doors, it is possible to access the major maintenance points from ground level. Furthermore, the fuel drain valve, engine oil filter, swing machinery oil filler, and PTO oil filler are remote mounted, facilitating easy maintenance.

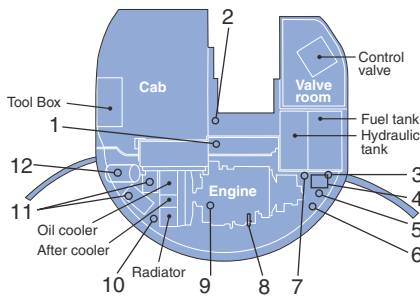

- 1. Swing machinery oil filler
- 2. Swing machinery dip stick
- 3. Fuel filter (with water separator)
- 4. Coolant reserve tank
- 5. Fuel drain valve
- 6. PTO oil filler
- 7. Engine oil filter
- 8. Engine oil dipstick
- 9. Engine oil filler
- 10. Windshield washer tank
- 11. Batteries
- 12. Air cleaner

Side-by-side Cooling

Since oil cooler, aftercooler and radiator are arranged side by side, it is easy to clean, remove, and install them.

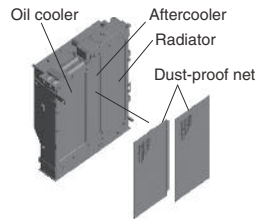

Large Tool Box

Large tool box provides plenty of space. Grease pump storage space is also provided.



Equipped with the Fuel Pre-filter (with Water Separator)

Removes water and contaminants in the fuel to help prevent fuel problems (with built in priming pump).



High-Pressure In-Line Filters

Installed at the pump discharge ports, this system provides additional hydraulic system protection from contamination.

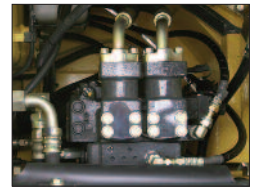

Photo may include optional equipment.

Maintenance Costs Reduced

Eco-white Filter Element

High performance filters are used in the hydraulic circuit and engine. Longer hydraulic oil, hydraulic oil filter, engine oil and engine oil filter element replacement intervals significantly reduce maintenance costs.

- Engine oil & Engine oil filter** every **500** hours
- Hydraulic oil** every **5000** hours
- Hydraulic oil filter** every **1000** hours



Longer Greasing Intervals

Special hard material is used for the bushings of the work equipment to lengthen greasing intervals. All bushing lubrication intervals of work equipment except arm tip and bucket linkage are 500 hours, reducing maintenance costs.

Large TFT LCD Monitor

Large multi-lingual LCD Monitor

A large user-friendly color monitor enables accurate and smooth work. Improved screen visibility is achieved by the use of Thin Film Transistor (TFT) Liquid Crystal Display (LCD) that can easily be read at various angles and lighting conditions. Simple and easy to operate switches. Industry first function keys facilitate multi-function operations. Displays data in 12 languages.

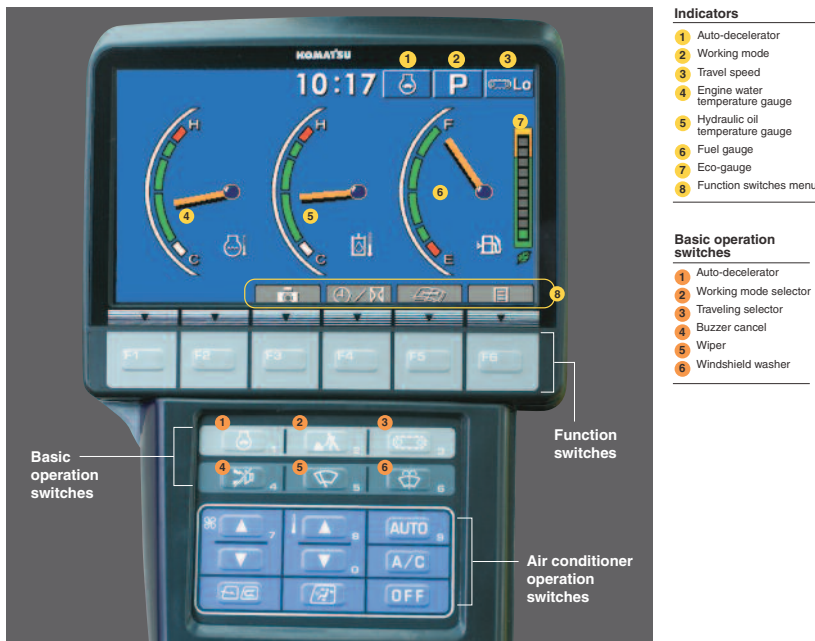

Equipment Management Monitoring System (EMMS)

Monitor function

Controller monitors engine oil level, coolant temperature, battery charge, etc. If the controller finds any abnormality, it is displayed on the LCD.



Maintenance function

Monitor informs replacement time of oil and filters on LCD when the replacement interval is reached.



Trouble data memory function

Monitor stores abnormalities for effective troubleshooting.

Excellent Reliability and Durability

High Rigidity Work Equipment

Boom and arms are constructed of thick plates of high tensile strength steel. In addition, these structures are designed with large cross-sectional areas and generous use of castings. The result is working attachments that exhibit long term durability and high resistance to bending and torsional stress.

Sturdy Frame Structure

The revolving frame, center frame, and undercarriage are designed by using the most advanced three-dimensional CAD and FEM analysis technology.

Metal Guard Rings Protect all the Hydraulic Cylinders and Improve Reliability.

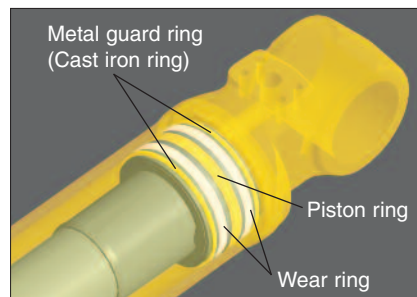

Reliable Components

All of the major machine components, such as engine, hydraulic pump, hydraulic motors, and control valves are exclusively designed and manufactured by Komatsu.

DT-type Connectors

DT-type connectors seal tight and have higher reliability.

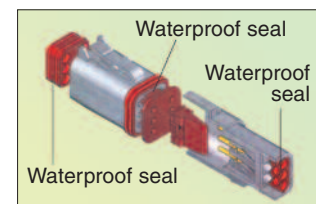

O-ring Face Seal

The hydraulic hose seal method has been changed from a conventional taper seal to an O-ring seal. This provides improved sealing performance.

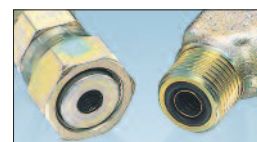



DIMENSIONS

	Boom Length	4600 mm	15'1"	4600 mm	15'1"
	Arm Length	2500 mm	8'2"	3000 mm	9'10"
A	Overall length	7385 mm	24'3"	7285 mm	23'11"
B	Overall height (to top of boom)	2850 mm	9'4"	3210 mm	10'6"
C	Length on ground (transport)	4540 mm	14'11"	4400 mm	14'5"

D	Overall width	2590 mm	8'6"
E	Overall height (to top of cab)	2815 mm	9'3"
F	Ground clearance, counterweight	900 mm	2'11"
G	Minimum ground clearance	395 mm	1'4"
H	Tail swing radius	1545 mm	5'1"
I	Length of track on ground	3140 mm	10'4"
J	Track length	3870 mm	12'8"
K	Track gauge	1990 mm	6'6"
L	Width of crawler	2590 mm	8'6"
M	Shoe width	600 mm	24"
N	Grouser height	20 mm	0.8"
O	Machine cab height	1980 mm	6'6"
P	Machine cab width	2490 mm	8'2"
Q	Distance swing center to rear end	1545 mm	5'1"

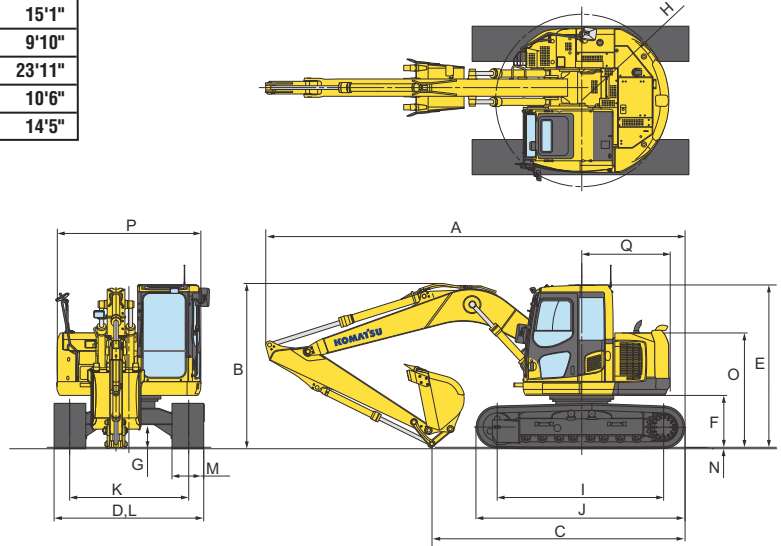

BACKHOE BUCKET AND ARM COMBINATION

Bucket Type	Bucket			Arms		
	Capacity	Width	Weight	2.5 m 8'2"	3.0 m 9'10"	
Komatsu GSK	0.26 m ³	0.34 yd ³	457 mm 18"	332 kg 732 lb	V	V
	0.38 m ³	0.50 yd ³	610 mm 24"	387 kg 853 lb	V	V
	0.51 m ³	0.67 yd ³	762 mm 30"	437 kg 963 lb	V	V
	0.63 m ³	0.83 yd ³	914 mm 36"	499 kg 1,099 lb	W	X
	0.76 m ³	1.00 yd ³	1067 mm 42"	559 kg 1,232 lb	X	Y
Komatsu HP	0.26 m ³	0.34 yd ³	457 mm 18"	379 kg 836 lb	V	V
	0.31 m ³	0.40 yd ³	508 mm 20"	396 kg 873 lb	V	V
	0.38 m ³	0.50 yd ³	610 mm 24"	457 kg 1,007 lb	V	V
	0.51 m ³	0.67 yd ³	762 mm 30"	517 kg 1,140 lb	V	W
	0.63 m ³	0.83 yd ³	914 mm 36"	591 kg 1,303 lb	W	X
Komatsu HPS	0.26 m ³	0.34 yd ³	457 mm 18"	406 kg 895 lb	V	V
	0.31 m ³	0.40 yd ³	508 mm 20"	426 kg 939 lb	V	V
	0.38 m ³	0.50 yd ³	610 mm 24"	493 kg 1,086 lb	V	V
	0.51 m ³	0.67 yd ³	762 mm 30"	562 kg 1,240 lb	V	W
	0.63 m ³	0.83 yd ³	914 mm 36"	645 kg 1,423 lb	X	Y
	0.76 m ³	1.00 yd ³	1067 mm 42"	728 kg 1,605 lb	Y	Z

V – Used with material density up to 3,500 lb/yd³, W – Used with material density up to 3,000 lb/yd³
 X – Used with material density up to 2,500 lb/yd³, Y – Used with material density up to 2,000 lb/yd³, Z – Not useable

WORKING RANGES



WORKING RANGE

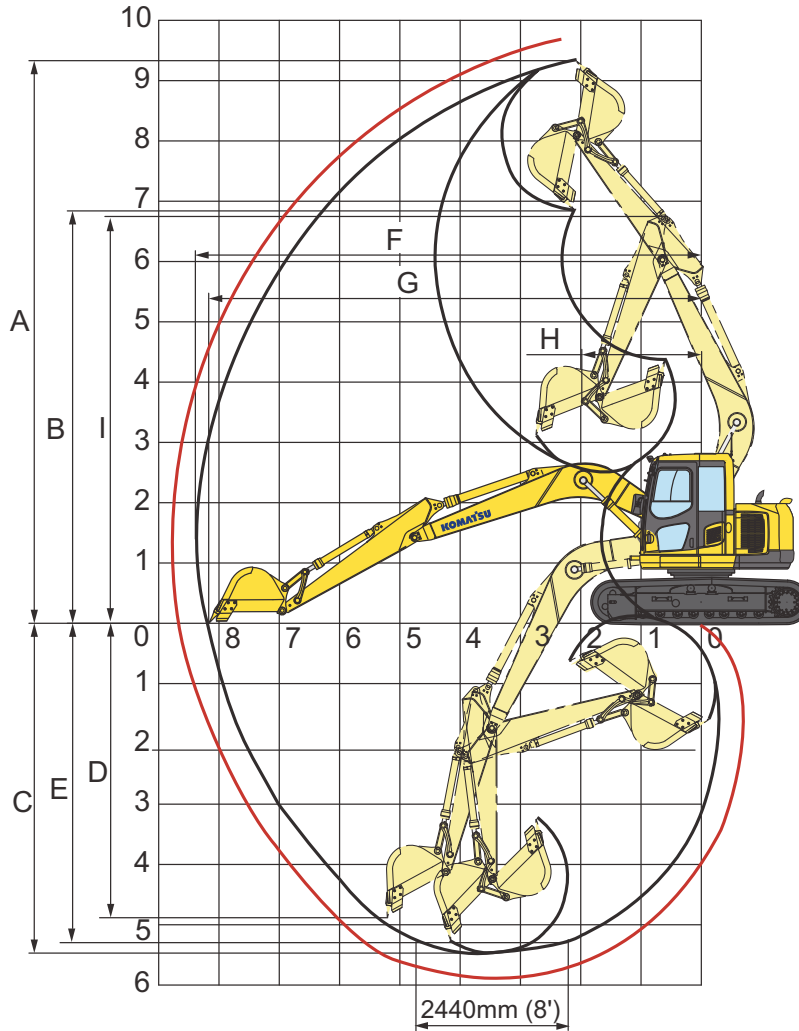

	Arm	2500 mm	8'2"	3000 mm	9'10"
A	Max. digging height	9340 mm	30'8"	9700 mm	31'10"
B	Max. dumping height	6840 mm	22'5"	7350 mm	24'1"
C	Max. digging depth	5480 mm	18'0"	5900 mm	19'4"
D	Max. vertical wall digging depth	4900 mm	16'1"	5340 mm	17'6"
E	Max. digging depth 8' level bottom	5265 mm	17'3"	5715 mm	18'9"
F	Max. digging reach	8300 mm	27'3"	8720 mm	28'7"
G	Max. digging reach at ground level	8180 mm	26'10"	8600 mm	28'3"
H	Min. swing radius	1980 mm	6'6"	2264 mm	7'5"
I	Max. height at min. swing radius	6770 mm	22'3"	6770 mm	22'3"

LIFTING CAPACITIES



LIFTING CAPACITY

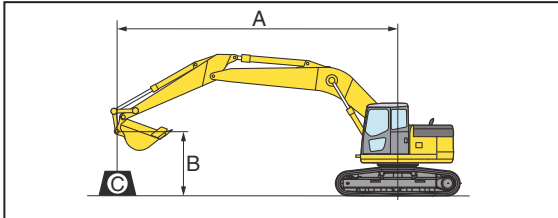

- A: Reach from swing center
- B: Bucket hook height
- C: Lifting capacity
- Cf: Rating over front
- Cs: Rating over side
- ☉: Rating at maximum reach

Conditions:

- Boom length: 4600 mm 15'11"
- Bucket: 0.50 m³ 0.65 yd³
- Bucket weight: 400 kg 883 lb.
- Lifting mode: On

Arm: 2500 mm 8'2"		Shoe: 500 mm 20"								Unit: kg lb			
B	A	1.5 m 5'		3.0 m 10'		4.6 m 15'		6.1 m 20'		7.6 m 25'		☉ Maximum	
		Cf	Cs	Cf	Cs	Cf	Cs	Cf	Cs	Cf	Cs	Cf	Cs
7.6 m 25'				*3130 *6,910	*3130 *6,910							*2160 *4,760	*2160 *4,760
6.1 m 20'						*3060 *6,750	*3060 *6,750					*1690 *3,730	*1690 *3,730
4.6 m 15'						*3420 *7,540	*3420 *7,540	*2730 *6,020	2150 4,740			*1570 *3,460	*1570 *3,460
3.0 m 10'				*5720 *12,620	*5720 *12,620	*4290 *9,460	3360 7,420	3510 7,730	2090 4,620			*1580 *3,490	*1580 *3,490
1.5 m 5'				*8190 *18,060	5960 13,140	*5260 *11,610	3170 6,990	3410 7,510	2000 4,430			*1690 *3,740	1490 3,290
0.0 m 0'				*6260 *13,810	5590 12,330	5270 11,630	3000 6,620	3320 7,330	1930 4,260			*1940 *4,280	1510 3,330
-1.5 m -5'		*3490 *7,700	*3490 *7,700	*8570 *18,890	5510 12,150	5180 11,430	2920 6,450	3280 7,240	1890 4,180			*2430 *5,360	1680 3,700
-3.0 m -10'		*7100 *15,650	*7100 *15,650	*7300 *16,100	5580 12,310	*4940 *10,910	2930 6,470					*3480 *7,670	2140 4,720
-4.6 m -15'													

* Load is limited by hydraulic capacity rather than tipping. Ratings are based on SAE Standard No. J1097. Rated loads do not exceed 87% of hydraulic lift capacity or 75% of tipping load.

Arm: 2500 mm 8'2"		Shoe: 600 mm 24"								Unit: kg lb			
B	A	1.5 m 5'		3.0 m 10'		4.6 m 15'		6.1 m 20'		7.6 m 25'		☉ Maximum	
		Cf	Cs	Cf	Cs	Cf	Cs	Cf	Cs	Cf	Cs	Cf	Cs
7.6 m 25'				*3130 *6,910	*3130 *6,910							*2160 *4,760	*2160 *4,760
6.1 m 20'						*3060 *6,750	*3060 *6,750					*1690 *3,730	*1690 *3,730
4.6 m 15'						*3420 *7,540	*3420 *7,540	*2730 *6,020	2180 4,800			*1570 *3,460	*1570 *3,460
3.0 m 10'				*5720 *12,620	*5720 *12,620	*4290 *9,460	3410 7,510	3550 7,840	2120 4,690			*1580 *3,490	*1580 *3,490
1.5 m 5'				*8190 *18,060	6030 13,300	*5260 *11,610	3210 7,080	3450 7,620	2030 4,490			*1690 *3,740	1510 3,340
0.0 m 0'				*6260 *13,810	5660 12,490	5340 11,790	3040 6,710	3370 7,440	1960 4,320			*1940 *4,280	1530 3,380
-1.5 m -5'		*3490 *7,700	*3490 *7,700	*8570 *18,890	5580 12,310	5250 11,580	2960 6,540	3330 7,340	1920 4,240			*2430 *5,360	1700 3,760
-3.0 m -10'		*7100 *15,650	*7100 *15,650	*7300 *16,100	5650 12,460	*4940 *10,910	2970 6,560					*3480 *7,670	2170 4,790
-4.6 m -15'													

* Load is limited by hydraulic capacity rather than tipping. Ratings are based on SAE Standard No. J1097. Rated loads do not exceed 87% of hydraulic lift capacity or 75% of tipping load.

PC138USLC-8 HYDRAULIC EXCAVATOR

LIFTING CAPACITIES



LIFTING CAPACITY (CONTINUED)

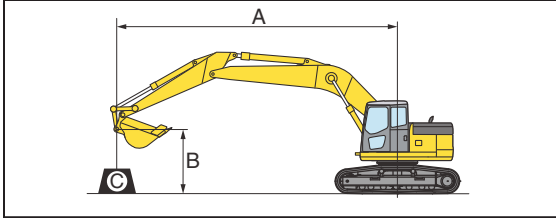

- A: Reach from swing center
- B: Bucket hook height
- C: Lifting capacity
- Cf: Rating over front
- Cs: Rating over side
- ⊗: Rating at maximum reach

Conditions:

- Boom length: 4600 mm 15'1"
- Bucket: 0.50 m³ 0.65 yd³
- Bucket weight: 400 kg 883 lb.
- Lifting mode: On

Arm: 2500 mm 8'2"		Shoe: 700 mm 28"								Unit: kg lb			
B	A	1.5 m 5'		3.0 m 10'		4.6 m 15'		6.1 m 20'		7.6 m 25'		⊗ Maximum	
		Cf	Cs	Cf	Cs	Cf	Cs	Cf	Cs	Cf	Cs	Cf	Cs
7.6 m 25'				*3130 *6,910	*3130 *6,910							*2160 *4,760	*2160 *4,760
6.1 m 20'						*3060 *6,750	*3060 *6,750					*1690 *3,730	*1690 *3,730
4.6 m 15'						*3420 *7,540	*3420 *7,540	*2730 *6,020	2210 4,870			*1570 *3,460	*1570 *3,460
3.0 m 10'				*5720 *12,620	*5720 *12,620	*4290 *9,460	3450 7,610	3600 7,950	2150 4,750			*1580 *3,490	*1580 *3,490
1.5 m 5'				*8190 *18,060	6110 13,470	*5260 *11,610	3250 7,180	3500 7,730	2060 4,560			*1690 *3,740	1540 3,390
0.0 m 0'				*6260 *13,810	5740 12,660	5420 11,960	3090 6,810	3420 7,550	1990 4,390			*1940 *4,280	1560 3,440
-1.5 m -5'		*3490 *7,700	*3490 *7,700	*8570 *18,890	5660 12,490	5330 11,750	3010 6,640	3380 7,460	1950 4,310			*2430 *5,360	1730 3,820
-3.0 m -10'		*7100 *15,650	*7100 *15,650	*7300 *16,100	5730 12,640	*4940 *10,910	3020 6,650					*3480 *7,670	2200 4,870
-4.6 m -15'													

* Load is limited by hydraulic capacity rather than tipping. Ratings are based on SAE Standard No. J1097. Rated loads do not exceed 87% of hydraulic lift capacity or 75% of tipping load.



LIFTING CAPACITY

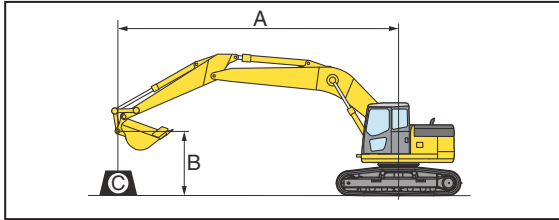

- A: Reach from swing center
- B: Bucket hook height
- C: Lifting capacity
- Cf: Rating over front
- Cs: Rating over side
- ☉: Rating at maximum reach

Conditions:

- Boom length: 4600 mm 15'1"
- Bucket: 0.36 m³ 0.5 yd³
- Bucket weight: 330 kg 730 lb.
- Lifting mode: On

Arm: 3000 mm 9'10"		Shoe: 500 mm 20"								Unit: kg lb			
B	A	1.5 m 5'		3.0 m 10'		4.6 m 15'		6.1 m 20'		7.6 m 25'		☉ Maximum	
		Cf	Cs	Cf	Cs	Cf	Cs	Cf	Cs	Cf	Cs	Cf	Cs
7.6 m 25'						*1770 *3,900	*1770 *3,900					*1690 *3,730	*1690 *3,730
6.1 m 20'						*2690 *5,940	*2690 *5,940	*1580 *3,480	*1580 *3,480			*1380 *3,050	*1380 *3,050
4.6 m 15'						*2740 *6,060	*2740 *6,060	*2630 *5,810	2180 4,820			*1280 *2,830	*1280 *2,830
3.0 m 10'				*3640 *8,030	*3640 *8,030	*3420 *7,560	*3420 *7,560	*3210 *7,070	2120 4,670			*1280 *2,830	*1280 *2,830
1.5 m 5'				*7690 *16,950	6080 13,410	*4870 *10,750	3190 7,040	3420 7,540	2010 4,440	*2080 *4,600	1360 3,010	*1360 *3,000	1310 2,900
0.0 m 0'				*7490 *16,530	5580 12,310	5260 11,610	2990 6,590	3310 7,300	1910 4,220	*1980 *4,370	1320 2,920	*1530 *3,370	1320 2,920
-1.5 m -5'		*3510 *7,750	*3510 *7,750	*8100 *17,870	5410 11,940	5130 11,320	2870 6,340	3240 7,160	1850 4,090			*1850 *4,100	1450 3,200
-3.0 m -10'		*6630 *14,630	*6630 *14,630	*7900 *17,430	5450 12,020	5120 11,290	2860 6,310	3250 7,170	1860 4,110			*2550 *5,630	1780 3,930
-4.6 m -15'				*5470 *12,060	*5470 *12,060	*3410 *7,530	2970 6,540					*2920 *6,440	2750 6,070

* Load is limited by hydraulic capacity rather than tipping. Ratings are based on SAE Standard No. J1097.
Rated loads do not exceed 87% of hydraulic lift capacity or 75% of tipping load.

Arm: 3000 mm 9'10"		Shoe: 600 mm 24"								Unit: kg lb			
B	A	1.5 m 5'		3.0 m 10'		4.6 m 15'		6.1 m 20'		7.6 m 25'		☉ Maximum	
		Cf	Cs	Cf	Cs	Cf	Cs	Cf	Cs	Cf	Cs	Cf	Cs
7.6 m 25'						*1770 *3,900	*1770 *3,900					*1690 *3,730	*1690 *3,730
6.1 m 20'						*2690 *5,940	*2690 *5,940	*1580 *3,480	*1580 *3,480			*1380 *3,050	*1380 *3,050
4.6 m 15'						*2740 *6,060	*2740 *6,060	*2630 *5,810	2210 4,880			*1280 *2,830	*1280 *2,830
3.0 m 10'				*3640 *8,030	*3640 *8,030	*3420 *7,560	*3420 *7,560	*3210 *7,070	2150 4,740			*1280 *2,830	*1280 *2,830
1.5 m 5'				*7690 *16,950	6150 13,560	*4870 *10,750	3230 7,130	3470 7,650	2040 4,500	*2080 *4,600	1380 3,050	*1360 *3,000	1330 2,950
0.0 m 0'				*7490 *16,530	5650 12,470	5330 11,770	3030 6,680	3360 7,400	1940 4,290	*1980 *4,370	1340 2,970	*1530 *3,370	1340 2,970
-1.5 m -5'		*3510 *7,750	*3510 *7,750	*8100 *17,870	5480 12,090	5200 11,470	2910 6,430	3290 7,260	1880 4,160			*1850 *4,100	1470 3,250
-3.0 m -10'		*6630 *14,630	*6630 *14,630	*7900 *17,430	5520 12,180	5180 11,420	2900 6,400	3300 7,270	1890 4,170			*2550 *5,630	1810 3,990
-4.6 m -15'				*5470 *12,060	*5470 *12,060	*3410 *7,530	3010 6,630					*2920 *6,440	2790 6,160

* Load is limited by hydraulic capacity rather than tipping. Ratings are based on SAE Standard No. J1097.
Rated loads do not exceed 87% of hydraulic lift capacity or 75% of tipping load.

LIFTING CAPACITIES



LIFTING CAPACITY (CONTINUED)

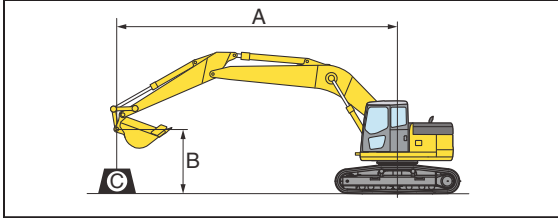

- A: Reach from swing center
- B: Bucket hook height
- C: Lifting capacity
- Cf: Rating over front
- Cs: Rating over side
- ⊗: Rating at maximum reach

Conditions:

- Boom length: 4600 mm 15'1"
- Bucket: 0.36 m³ 0.50 yd³
- Bucket weight: 330 kg 730 lb.
- Lifting mode: On

Arm: 3000 mm 9'10"		Shoe: 700 mm 28"										Unit: kg lb	
B	A	1.5 m 5'		3.0 m 10'		4.6 m 15'		6.1 m 20'		7.6 m 25'		⊗ Maximum	
		Cf	Cs	Cf	Cs	Cf	Cs	Cf	Cs	Cf	Cs	Cf	Cs
7.6 m 25'						*1770 *3,900	*1770 *3,900					*1690 *3,730	*1690 *3,730
6.1 m 20'						*2690 *5,940	*2690 *5,940	*1580 *3,480	*1580 *3,480			*1380 *3,050	*1380 *3,050
4.6 m 15'						*2740 *6,060	*2740 *6,060	*2630 *5,810	2240 4,950			*1280 *2,830	*1280 *2,830
3.0 m 10'				*3640 *8,030	*3640 *8,030	*3420 *7,560	*3420 *7,560	*3210 *7,070	2180 4,800			*1280 *2,830	*1280 *2,830
1.5 m 5'				*7690 *16,950	6230 13,740	*4870 *10,750	3270 7,220	3520 7,760	2070 4,570	*2080 *4,600	1410 3,110	*1360 *3,000	*1360 *3,000
0.0 m 0'				*7490 *16,530	5730 12,640	5410 11,940	3070 6,780	3410 7,520	1970 4,350	*1980 *4,370	1370 3,020	*1530 *3,370	1370 3,020
-1.5 m -5'		*3510 *7,750	*3510 *7,750	*8100 *17,870	5560 12,270	5280 11,640	2960 6,530	3340 7,370	1910 4,220			*1850 *4,100	1500 3,310
-3.0 m -10'		*6630 *14,630	*6630 *14,630	*7900 *17,430	5600 12,350	5250 11,590	2950 6,500	3350 7,390	1920 4,240			*2550 *5,630	1840 4,060
-4.6 m -15'				*5470 *12,060	*5470 *12,060	*3410 *7,530	3050 6,730					*2920 *6,440	2830 6,250

* Load is limited by hydraulic capacity rather than tipping. Ratings are based on SAE Standard No. J1097. Rated loads do not exceed 87% of hydraulic lift capacity or 75% of tipping load.



STANDARD EQUIPMENT

- Air cleaner, dry type, double element with auto dust evacuator
- Auto air conditioner
- Alternator, 35 Ampere, 24 V
- Auto-decel
- Automatic engine warm-up system
- Batteries, 64 Ah/2 x 12 V
- Boom holding valves
- Cab which includes: antenna, AM/FM radio, floor mat, intermittent front windshield wiper and washer, large ceiling hatch, pull-up front window, removable lower windshield, sliding seat
- Cooling fan, mixed flow with fan guard
- Counterweight, 3750 kg **8,270 lb**
- Electric horn
- EMMS monitoring system
- Engine, Komatsu SAA4D95LE-5
- Engine overheat prevention system
- Extended work equipment grease interval
- Fuel system pre-filter 10 micron
- High back suspension seat
- High pressure in-line filters
- Hydraulic track adjusters (each side)
- KOMTRAX®
- Light, one front
- Multi-function color monitor
- Pattern change valve
- PPC hydraulic control system
- Pump/engine partition
- Radiator and oil cooler dustproof net
- Seat belt, retractable 76 mm **3"** wide
- Service valve (1 additional)
- Shoe, 600 mm **24"** triple grouser
- Slip resistant plates
- Starting motor 4.5 kW
- Swing holding brake
- Travel alarm
- Rear view camera
- Working mode selection system



OPTIONAL EQUIPMENT

- Arms
 - 2100 mm **6'11"** arm assembly
 - 2500 mm **8'2"** arm assembly
 - 2500 mm **8'2"** arm with piping
 - 3000 mm **9'10"** arm assembly
- Blade assembly, **8'6"** wide (Welded cutting edge type)
- Bolt-on top guard, (operator protective guards level 2)
- Boom
 - 4600 mm **15'1"** boom assembly
 - 4600 mm **15'1"** boom with piping
- Cab front guard
 - Full height guard (level 1)
 - Full height guard (level 2)
- Hydraulic control unit
 - 1 additional actuator
- Shoes
 - 600 mm **24"** triple grouser
 - 700 mm **28"** triple grouser
 - 500 mm **20"** rubber pad (road liner)
 - 500 mm **20"** triple grouser
- Sun visor
- Track frame undercover



AESS742-01

©2007 Komatsu America Corp.

Printed in USA

DK(7.5M)04/06 D(3M)01/09C

01/09 (EV-2)

KOMATSU[®]

www.KomatsuAmerica.com

Komatsu America Corp. is an authorized licensee of Komatsu Ltd. Materials and specifications are subject to change without notice. **KOMATSU** is a registered trademark of Komatsu Ltd., Japan. KOMTRAX[®] is a trademark of Komatsu America Corp.